

American Standard

HEATING & AIR CONDITIONING

Upflow/Horizontal Right or Upflow/Horizontal Left Induced Draft Gas Furnace

American Standard 80 Furnace

AUE1A040A9241A, AUE1A060A9241A, AUE1A060A9361A
AUE1B060A9361A, AUE1B080A9361A, AUE1B080A9481A
AUE1B100A9361A, AUE1C100A9481A, AUE1C100A9601A
AUE1D120A9601A, AUE1D140A9601A

Single-Stage Fan Assisted
Combustion System

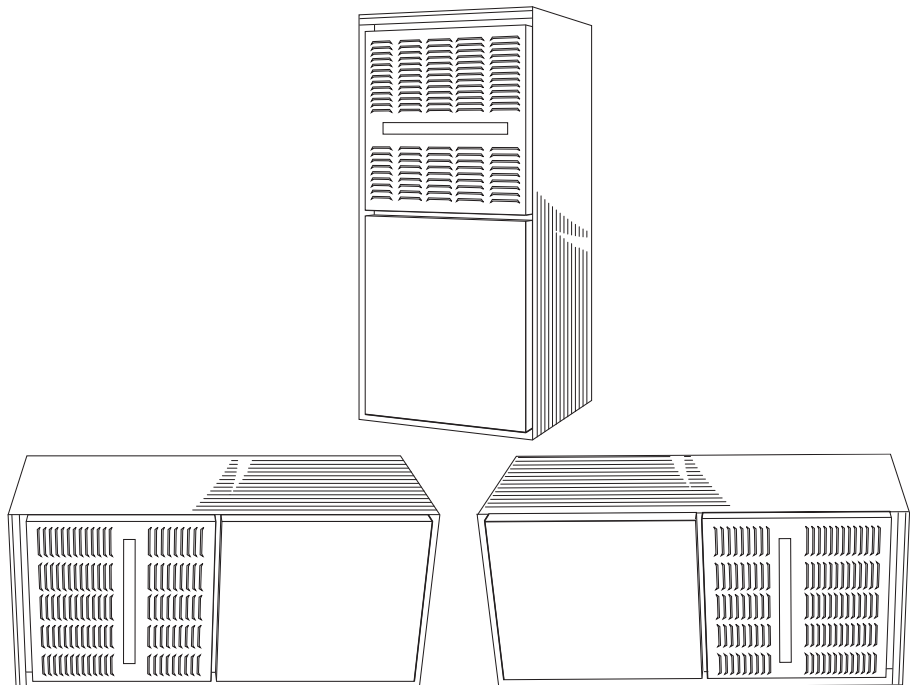

PUB. NO. 12-1236-04

General Features

NATURAL GAS MODELS

Central Heating furnace designs are certified by the American Gas Association for both natural and L.P. gas. Limit setting and rating data were established and approved under standard rating conditions using American National Standards Institute standards.

SAFE OPERATION

The Integrated System Control has solid state devices, which continuously monitor for presence of flame, when the system is in the heating mode of operation. Dual solenoid combination gas valve and regulator provide extra safety.

QUICK HEATING

Durable, cycle tested, heavy gauge **aluminized steel heat exchanger** quickly transfers heat to provide warm conditioned air to the structure.

BURNERS

Multiport Inshot burners will give years of quiet and efficient service. All models can be converted to **L.P. gas**.

INTEGRATED SYSTEM CONTROL

Exclusively designed operational program provides total control of furnace limit sensors, blowers, gas valve, flame control and includes self diagnostics for ease of service. Also contains connection points for E.A.C./humidifier.

AIR DELIVERY

The 4-speed, direct drive blower motor, has sufficient airflow for most heating and cooling requirements, will switch from heating to cooling speeds on demand from room thermostat. The blower door safety switch will prevent or terminate furnace operation when the blower door is removed.

STYLING

Heavy gauge steel and “wrap-around” cabinet construction is used in the cabinet with baked-on enamel finish for strength and beauty. The heat exchanger section of the cabinet is completely lined with foil faced fiberglass insulation. This results in quiet and efficient operation due to the excellent acoustical and insulating qualities of fiberglass. Alternate bottom, left or right side return air connection provision capability.

FEATURES AND GENERAL OPERATION

The American Standard 80 Gas Furnaces employs an Hot Surface Ignition system, which eliminates the waste of a constant burning pilot. The integrated system control lights the main burners upon a demand for heat from the room thermostat. Complete front service access.

- a. Low energy power venter
- b. Vent proving pressure switch.

Contents

Feature Summary	2
Features and Benefits	4
Standard Equipment	
Optional Equipment	
General Data	5
AUE1A040A9241A	
AUE1A060A9241A	
AUE1A060A9361A	
AUE1B060A9361A	
AUE1B080A9361A	
AUE1B080A9481A	
AUE1B100A9361A	
AUE1C100A9481A	
AUE1C100A9601A	
AUE1D120A9601A	
AUE1D140A9601A	
Performance Data	8
Electrical Data	10
Field Wiring	12
Dimensions	13

Features and Benefits

80 FURNACE STANDARD EQUIPMENT

- Convertible to horizontal left or right
- Power supply 115/1/60
- Single speed venter
- Silicon Nitride hot surface igniter with adaptive heat up
- Integrated system control
- Attractive color accents
- Heavy gauge aluminized steel heat exchanger
- Direct drive 4-speed motor
- Blower door safety switch
- Multiport In-shot burners
- Complete front service access
- Alternate bottom/left/right return air in vertical position
- Slide out blower assembly
- Common vent capability
- Heavy gauge reinforced wrap-around steel cabinet
- Super quiet performance
- Optional L.P. conversion kit
- Left/right gas connection

80 FURNACE OPTIONAL ACCESSORIES

OPTIONAL EQUIPMENT (Check mark [✓] indicates accessories included).

For Comfort Controls, See price book pages	[]
AccuClean™ Whole House Air Cleaner (14-1/2" Wide, Upflow / Side Return Furnace).....	AFD145ALFR000A []
AccuClean™ Whole House Air Cleaner (17-1/2" Wide, Upflow / Side Return Furnace).....	AFD175ALFR000A []
AccuClean™ Whole House Air Cleaner (21" Wide, Upflow / Side Return Furnace).....	AFD210ALFR000A []
AccuClean™ Whole House Air Cleaner (24-1/2" Wide, Upflow / Side Return Furnace).....	AFD245ALFR000A []
AccuClean™ Whole House Air Cleaner (14-1/2" Wide, Downflow Furnace)	AFD14DALFR000A []
AccuClean™ Whole House Air Cleaner (17-1/2" Wide, Downflow Furnace)	AFD17DALFR000A []
AccuClean™ Whole House Air Cleaner (21" Wide, Downflow Furnace)	AFD21DALFR000A []
AccuClean™ Whole House Air Cleaner (24-1/2" Wide, Downflow Furnace)	AFD24DALFR000A []
Air Filter, "Perfect Fit" High Efficiency (14-1/2" Wide Gas Furnace)	TFM145A9FR0 []
Air Filter, "Perfect Fit" High Efficiency (17-1/2" Wide Gas Furnace)	TFM175A9FR0 []
Air Filter, "Perfect Fit" High Efficiency (21" Wide Gas Furnace).....	TFM210A9FR0 []
Air Filter, "Perfect Fit" High Efficiency (24-1/2" Wide Gas Furnace)	TFM245A9FR0 []
Air Filter, "Perfect Fit" Standard Efficiency (14-1/2" Wide Gas Furnace)	TFP145A9FR0 []
Air Filter, "Perfect Fit" Standard Efficiency (17-1/2" Wide Gas Furnace)	TFP175A9FR0 []
Air Filter, "Perfect Fit" Standard Efficiency (21" Wide Gas Furnace)	TFP210A9FR0 []
Air Filter, "Perfect Fit" Standard Efficiency (24-1/2" Wide Gas Furnace)	TFP245A9FR0 []
Coil Enclosure (14-1/2" Wide Cabinets)	BAYCLE14A1422A []
Coil Enclosure (17-1/2" Wide Cabinets)	BAYCLE17A1722A []
Coil Enclosure (21" Wide Cabinets)	BAYCLE21A2130A []
Coil Enclosure (24-1/2" Wide Cabinets)	BAYCLE24A2430A []
Filter Rack Kit	BAYRACK960A []
High Altitude Switch.....	BAYHALT248 []
Downflow Subbase	BAYBASE205 []
Propane Conversion Kit.....	BAYLPKT210B []
Propane Conversion Kit (With Stainless Steel burners)	BAYLPSS210B []
Masonry Chimney Vent Kit (Upflow models only).....	BAYVENT800B []
Cleanable Filter (14.5" / 17.5" wide upflow models)	BAYFLTR317 []
Cleanable Filter (21" wide upflow models)	BAYFLTR321 []
Cleanable Filter (24.5" wide upflow models)	BAYFLTR324 []
Filter Access Door Kit (Downflow models only).....	BAYFLTR206 []

General Data

PRODUCT SPECIFICATIONS ①

MODEL	AUE1A040A9241A	AUE1A060A9241A	AUE1A060A9361A	AUE1B060A9361A
TYPE	Upflow / Horizontal	Upflow / Horizontal	Upflow / Horizontal	Upflow / Horizontal
RATINGS ②				
Input BTUH	40,000	60,000	60,000	60,000
Capacity BTUH (ICS) ③	31,000	47,000	47,000	47,000
AFUE (ICS)	80.0	80.0	80.0	80.0
Temp. rise (Min.-Max.) °F	30 - 60	35 - 65	30 - 60	30 - 60
BLOWER DRIVE	Direct	Direct	Direct	Direct
Diameter - Width (In.)	10 x 6	10 x 6	10 x 6	10 x 7
No. Used	1	1	1	1
Speeds (No.)	4	4	4	4
CFM vs. in. w.g.	See Fan Performance Table	See Fan Performance Table	See Fan Performance Table	See Fan Performance Table
Motor HP	1/5	1/5	1/3	1/3
R.P.M.	1080	1080	1075	1075
Volts/Ph/Hz	115/1/60	115/1/60	115/1/60	115/1/60
COMBUSTION FAN - Type	Centrifugal	Centrifugal	Centrifugal	Centrifugal
Drive - No. Speeds	Direct - 1	Direct - 1	Direct - 1	Direct - 1
Motor HP - RPM	1/50 - 3180	1/50 - 3180	1/50 - 3180	1/50 - 3180
Volts/Ph/Hz	115/1/60	115/1/60	115/1/60	115/1/60
FLA	1.09	1.09	1.09	1.09
FILTER — Furnished?	No	No	No	No
Type Recommended	High Velocity	High Velocity	High Velocity	High Velocity
Hi Vel. (No.-Size-Thk.)	1 - 16x25 - 1in.	1 - 17x25 - 1in.	1 - 16x25 - 1in.	1 - 16x25 - 1in.
VENT — Size (in.)	4 Round	4 Round	4 Round	4 Round
HEAT EXCHANGER				
Type-Fired	Alum. Steel	Alum. Steel	Alum. Steel	Alum. Steel
-Unfired	-	-	-	-
Gauge (Fired)	20	20	20	20
ORIFICES — Main				
Nat. Gas. Qty. — Drill Size	2 — 45	3 — 45	3 — 45	3 — 45
L.P. Gas Qty. — Drill Size	2 — 56	3 — 56	3 — 56	3 — 56
GAS VALVE	Redundant - Single Stage	Redundant - Single Stage	Redundant - Single Stage	Redundant - Single Stage
PILOT SAFETY DEVICE				
Type	Hot Surface Ignition	Hot Surface Ignition	Hot Surface Ignition	Hot Surface Ignition
BURNERS — Type				
Number	Multiport Inshot 2	Multiport Inshot 3	Multiport Inshot 3	Multiport Inshot 3
POWER CONN. — V/Ph/Hz ④	115/1/60	115/1/60	115/1/60	115/1/60
Ampacity (In Amps)	5.4	5.4	9.0	9.0
Max. Overcurrent Protection (Amps)	15	15	15	15
PIPE CONN. SIZE (IN.)	1/2	1/2	1/2	1/2
DIMENSIONS				
Crated (In.)	H x W x D 41-3/4 x 16-1/2 x 30-1/2	H x W x D 41-3/4 x 16-1/2 x 30-1/2	H x W x D 41-3/4 x 16-1/2 x 30-1/2	H x W x D 41-3/4 x 19-1/2 x 30-1/2
WEIGHT				
Shipping (Lbs.)/Net (Lbs)	119 / 110	124 / 115	127 / 118	137 / 127

① Central Furnace heating designs are certified to ANSI Z21.47 and CSA 2.3.

② For U.S. applications, above input ratings (BTUH) are up to 2,000 feet, derate 4% per 1,000 feet for elevations above 2,000 feet above sea level. For Canadian applications, above input ratings (BTUH) are up to 4,500 feet, derate 4% per 1,000 feet for elevations above 4,500 feet above sea level.

③ Based on U.S. government standard tests.

④ The above wiring specifications are in accordance with National Electrical Code; however, installations must comply with local codes.

General Data

PRODUCT SPECIFICATIONS ①

MODEL	AUE1B080A9361A	AUE1B080A9481A	AUE1B100A9361A	AUE1C100A9481A
TYPE	Upflow/Horizontal	Upflow/Horizontal	Upflow/Horizontal	Upflow/Horizontal
RATINGS ②				
Input BTUH	80,000	80,000	100,000	100,000
Capacity BTUH (ICS) ③	63,000	64,000	79,000	79,000
AFUE (ICS)	80.0	80.0	80.0	80.0
Temp. rise (Min.-Max.) °F	30 - 60	30 - 60	40 - 70	35 - 65
BLOWER DRIVE	Direct	Direct	Direct	Direct
Diameter - Width (In.)	10 x 7	10 x 8	10 x 7	10 x 8
No. Used	1	1	1	1
Speeds (No.)	4	4	4	4
CFM vs. in. w.g.	See Fan Performance Table	See Fan Performance Table	See Fan Performance Table	See Fan Performance Table
Motor HP	1/3	1/3	1/3	1/2
R.P.M.	1075	1075	1075	1075
Volts / Ph / Hz	115/1/60	115/1/60	115/1/60	115/1/60
COMBUSTION FAN - Type	Centrifugal	Centrifugal	Centrifugal	Centrifugal
Drive - No. Speeds	Direct - 1	Direct - 1	Direct - 1	Direct - 1
Motor HP - RPM	1/50 - 3180	1/50 - 3180	1/50 - 3180	1/50 - 3180
Volts / Ph / Hz	115/1/60	115/1/60	115/1/60	115/1/60
FLA	1.09	1.09	1.09	1.09
FILTER — Furnished?	No	No	No	No
Type Recommended	High Velocity	High Velocity	High Velocity	High Velocity
Hi Vel. (No.-Size-Thk.)	1 - 17x25 - 1in.	1 - 17x25 - 1in.	1 - 17x25 - 1in.	1 - 20x25 - 1in.
VENT — Size (in.)	4 Round	4 Round	4 Round	4 Round
HEAT EXCHANGER				
Type-Fired	Alum. Steel	Alum. Steel	Alum. Steel	Alum. Steel
-Unfired				
Gauge (Fired)	20	20	20	20
ORIFICES — Main				
Nat. Gas. Qty. — Drill Size	4 — 45	4 — 45	5 — 45	5 — 45
L.P. Gas Qty. — Drill Size	4 — 56	4 — 56	5 — 56	5 — 56
GAS VALVE	Redundant - Single Stage	Redundant - Single Stage	Redundant - Single Stage	Redundant - Single Stage
PILOT SAFETY DEVICE				
Type	Hot Surface Ignition	Hot Surface Ignition	Hot Surface Ignition	Hot Surface Ignition
BURNERS — Type	Multiport Inshot	Multiport Inshot	Multiport Inshot	Multiport Inshot
Number	4	4	5	5
POWER CONN. — V/Ph/Hz ④	115/1/60	115/1/60	115/1/60	115/1/60
Ampacity (In Amps)	9.0	9.8	9.0	11.6
Max. Overcurrent Protection (Amps)	15	15	15	15
PIPE CONN. SIZE (IN.)	1/2	1/2	1/2	1/2
DIMENSIONS				
Crated (In.)	H x W x D 41-3/4 x 19-1/2 x 30-1/2	H x W x D 41-3/4 x 19-1/2 x 30-1/2	H x W x D 41-3/4 x 19-1/2 x 30-1/2	H x W x D 41-3/4 x 23 x 30-1/2
WEIGHT				
Shipping (Lbs.)/Net (Lbs)	142 / 132	142 / 132	151 / 141	162 / 151

① Central Furnace heating designs are certified to ANSI Z21.47 and CSA 2.3.

② For U.S. applications, above input ratings (BTUH) are up to 2,000 feet, derate 4% per 1,000 feet for elevations above 2,000 feet above sea level. For Canadian applications, above input ratings (BTUH) are up to 4,500 feet, derate 4% per 1,000 feet for elevations above 4,500 feet above sea level.

③ Based on U.S. government standard tests.

④ The above wiring specifications are in accordance with National Electrical Code; however, installations must comply with local codes.

General Data

PRODUCT SPECIFICATIONS ①

MODEL	AUE1C100A9601A	AUE1D120A9601A	AUE1D140A9601A
TYPE	Upflow/Horizontal	Upflow/Horizontal	Upflow/Horizontal
RATINGS ②			
Input BTUH	100,000	120,000	140,000
Capacity BTUH (ICS) ③	79,000	96,000	111,000
AFUE (ICS)	80.0	80.0	80.0
Temp. rise (Min.-Max.) °F	30 - 60	30 - 60	40 - 70
BLOWER DRIVE	Direct	Direct	DIRECT
Diameter - Width (In.)	11 x 10	11 x 10	11 x 10
No. Used	1	1	1
Speeds (No.)	4	4	4
CFM vs. in. w.g.	See Fan Performance Table	See Fan Performance Table	See Fan Performance Table
Motor HP	1/2	1/2	3/4
R.P.M.	1075	1075	1075
Volts/Ph/Hz	115/1/60	115/1/60	115/1/60
COMBUSTION FAN - Type	Centrifugal	Centrifugal	Centrifugal
Drive - No. Speeds	Direct - 1	Direct - 1	Direct - 1
Motor HP - RPM	1/50 - 3180	1/50 - 3180	1/50 - 3180
Volts/Ph/Hz	115/1/60	115/1/60	115/1/60
FLA	1.09	1.09	1.09
FILTER — Furnished?	No	No	No
Type Recommended	High Velocity	High Velocity	High Velocity
Hi Vel. (No.-Size-Thk.)	1 - 20x25 - 1in.	1 - 24x25 - 1in.	1 - 24x25 - 1in.
VENT — Size (in.)	4 Round	4 Round	4 Round
HEAT EXCHANGER			
Type-Fired	Alum. Steel	Alum. Steel	Alum. Steel
-Unfired			
Gauge (Fired)	20	20	20
ORIFICES — Main			
Nat. Gas. Qty. — Drill Size	5 — 45	6 — 45	7 — 45
L.P. Gas Qty. — Drill Size	5 — 56	6 — 56	7 — 56
GAS VALVE	Redundant - Single Stage	Redundant - Single Stage	Redundant - Single Stage
PILOT SAFETY DEVICE			
Type	Hot Surface Ignition	Hot Surface Ignition	Hot Surface Ignition
BURNERS — Type	Multiport Inshot	Multiport Inshot	Multiport Inshot
Number	5	6	7
POWER CONN. — V/Ph/Hz ④	115/1/60	115/1/60	115/1/60
Ampacity (In Amps)	13.4	13.4	13.8
Max. Overcurrent Protection (Amps)	15	20	20
PIPE CONN. SIZE (IN.)	1/2	1/2	1/2
DIMENSIONS			
Crated (In.)	H x W x D 41-3/4 x 23 x 30-1/2	H x W x D 41-3/4 x 26-1/2 x 30-1/2	H x W x D 41-3/4 x 26-1/2 x 30-1/2
WEIGHT			
Shipping (Lbs.)/Net (Lbs)	162 / 151	186 / 174	193 / 181

① Central Furnace heating designs are certified to ANSI Z21.47 and CSA 2.3.

② For U.S. applications, above input ratings (BTUH) are up to 2,000 feet, derate 4% per 1,000 feet for elevations above 2,000 feet above sea level. For Canadian applications, above input ratings (BTUH) are up to 4,500 feet, derate 4% per 1,000 feet for elevations above 4,500 feet above sea level.

③ Based on U.S. government standard tests.

④ The above wiring specifications are in accordance with National Electrical Code; however, installations must comply with local codes.

Performance Data

FURNACE AIRFLOW (CFM) VS. EXTERNAL STATIC PRESSURE (IN. W.C.)										
MODEL	SPEED TAP	0.10	0.20	0.30	0.40	0.50	0.60	0.70	0.80	0.90
AUE1A040A9241A	4 - HIGH - Black	1018	1004	982	950	910	860	802	763	660
	3 - MED.-HIGH - Blue	847	832	809	779	742	697	644	585	517
	2 - MED.-LOW - Yellow	716	701	678	648	610	585	512	452	384
	1 - LOW - Red	617	599	575	544	507	463	413	357	294
AUE1A060A9241A	4 - HIGH - Black	1018	997	973	941	901	852	796	731	659
	3 - MED.-HIGH - Blue	835	821	800	771	734	689	636	575	506
	2 - MED.-LOW - Yellow	712	702	683	655	617	571	516	452	379
	1 - LOW - Red	611	596	573	543	505	459	406	345	277
AUE1A060A9361A	4 - HIGH - Black	1426	1389	1345	1298	1236	1171	1099	1020	934
	3 - MED.-HIGH - Blue	1243	1225	1197	1160	1113	1057	991	916	831
	2 - MED.-LOW - Yellow	1042	1039	1027	1005	973	931	879	817	745
	1 - LOW - Red	900	903	895	877	848	809	760	700	629
AUE1B060A9361A	4 - HIGH - Black	1426	1389	1345	1298	1236	1171	1099	1020	934
	3 - MED.-HIGH - Blue	1243	1225	1197	1160	1113	1057	991	916	831
	2 - MED.-LOW - Yellow	1042	1039	1027	1005	973	931	879	817	745
	1 - LOW - Red	900	903	895	877	848	809	760	700	629
AUE1B080A9361A	4 - HIGH - Black	1393	1384	1364	1335	1296	1247	1189	1120	1042
	3 - MED.-HIGH - Blue	1210	1209	1198	1177	1147	1107	1058	999	930
	2 - MED.-LOW - Yellow	1046	1052	1047	1033	1008	973	928	873	808
	1 - LOW - Red	900	903	895	888	869	842	808	766	717
AUE1B100A9361A	4 - HIGH - Black	1476	1464	1441	1408	1363	1307	1241	1163	1074
	3 - MED.-HIGH - Blue	1249	1257	1252	1234	1203	1158	1101	1030	946
	2 - MED.-LOW - Yellow	1020	1046	1058	1050	1028	990	936	866	780
	1 - LOW - Red	873	887	890	883	864	834	794	742	680
AUE1B080A9481A	4 - HIGH - Black	1839	1821	1796	1756	1710	1641	1573	1480	1392
	3 - MED.-HIGH - Blue	1323	1325	1329	1319	1308	1275	1246	1201	1165
	2 - MED.-LOW - Yellow	1092	1090	1091	1083	1076	1059	1040	1005	970
	1 - LOW - Red	788	783	780	768	758	737	719	674	630
AUE1C100A9481A	4 - HIGH - Black	1880	1846	1799	1740	1669	1595	1489	1381	1260
	3 - MED.-HIGH - Blue	1662	1635	1598	1551	1493	1424	1345	1256	1157
	2 - MED.-LOW - Yellow	1428	1421	1402	1370	1326	1269	1199	1117	1022
	1 - LOW - Red	1208	1215	1210	1193	1164	1124	1073	1009	935
AUE1C100A9601A	4 - HIGH - Black	2181	2143	2104	2053	2001	1929	1856	1766	1676
	3 - MED.-HIGH - Blue	1908	1888	1868	1834	1800	1745	1690	1631	1572
	2 - MED.-LOW - Yellow	1621	1609	1597	1582	1567	1533	1498	1438	1377
	1 - LOW - Red	1443	1419	1395	1381	1367	1335	1302	1256	1209
AUE1D120A9601A	4 - HIGH - Black	2135	2101	2066	2036	2005	1923	1840	1750	1659
	3 - MED.-HIGH - Blue	1906	1881	1856	1817	1777	1724	1671	1602	1533
	2 - MED.-LOW - Yellow	1646	1632	1617	1596	1575	1535	1494	1427	1360
	1 - LOW - Red	1423	1415	1407	1391	1375	1338	1300	1246	1192
AUE1D140A9601A	4 - HIGH - Black	2462	2407	2351	2284	2216	2143	2069	1989	1908
	3 - MED.-HIGH - Blue	2128	2112	2096	2054	2011	1949	1887	1797	1706
	2 - MED.-LOW - Yellow	1755	1746	1736	1719	1702	1656	1609	1564	1518
	1 - LOW - Red	1450	1446	1442	1427	1411	1383	1354	1298	1241

From D330672 Rev. 17

Performance Data

CFM VS. TEMPERATURE RISE																				
MODEL	CFM (CUBIC FEET PER MINUTE)																			
	500	600	700	800	900	1000	1100	1200	1300	1400	1500	1600	1700	1800	1900	2000	2100	2200	2300	2400
AUE1A040A9241A	54	49	42	37	33	30														
AUE1A060A9241A			63	56	49	44														
AUE1A060A9361A				56	49	44	40	37	34	32										
AUE1B060A9361A				56	49	44	40	37	34	32										
AUE1B080A9361A						59	54	49	46	42										
AUE1B100A9361A						58	52	49	46	42	40	37	35	33						
AUE1B080A9481A							67	62	57	53	49									
AUE1C100A9481A							67	62	57	53	49	46	44	41	39	37				
AUE1C100A9601A								62	57	53	49	46	44	41	39	37	35	34	32	31
AUE1D120A9601A											59	56	52	49	47	44	42	40		
AUE1D140A9601A											69	65	61	58	55	52	49	47	45	

From C340782 Sh.1 Rev. 8

Field Wiring

WIRING DIAGRAM FOR AUE1 GAS FURNACES

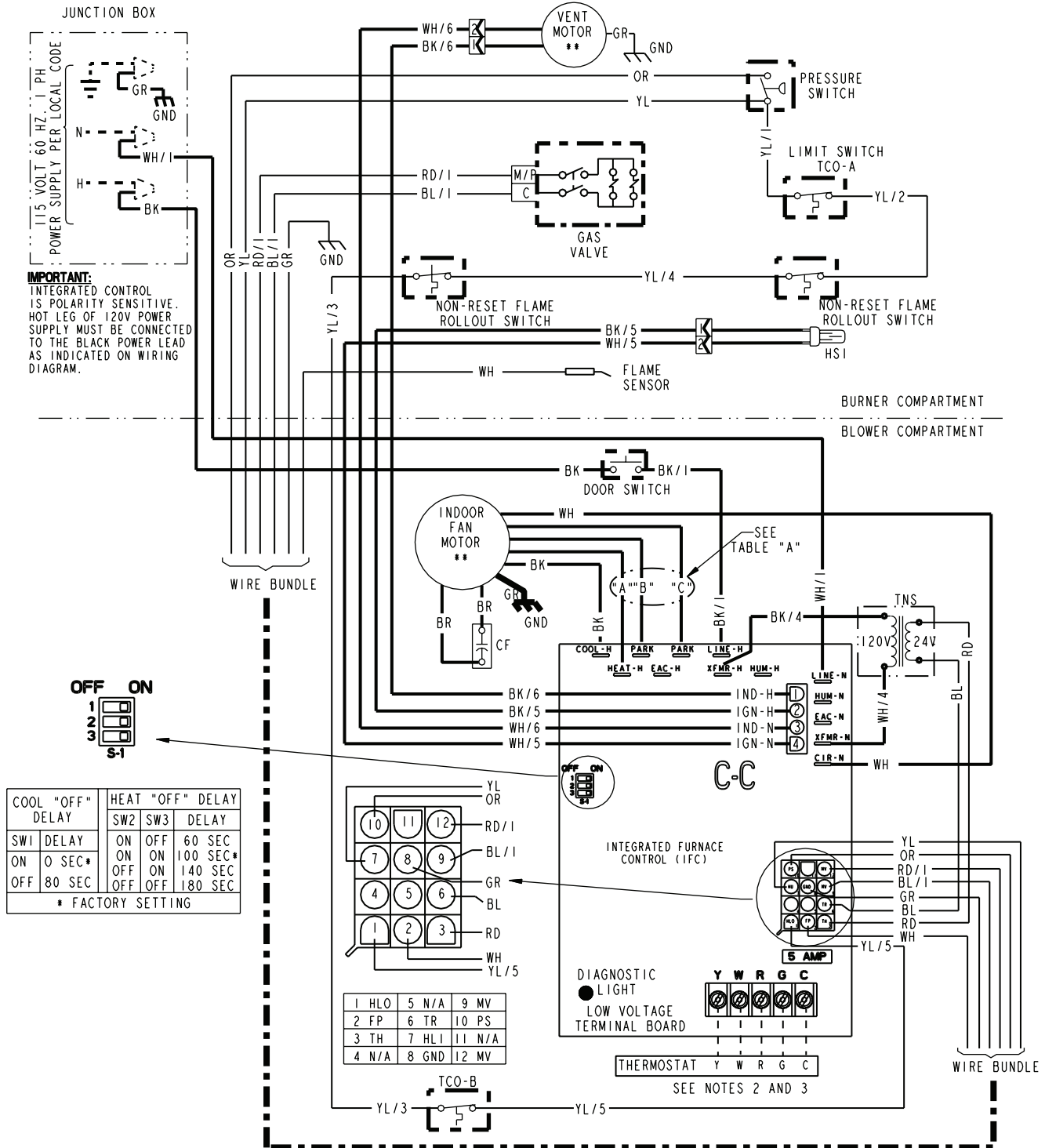

From Dwg. D342779

Field Wiring

FIELD WIRING DIAGRAM FOR HEATING ONLY

FIELD WIRING DIAGRAM FOR 1 STAGE FURNACE 1 STAGE HEATING USING A 1 STAGE HEATING THERMOSTAT NO COOLING

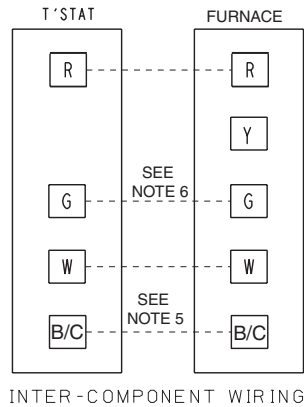

INTER-COMPONENT WIRING

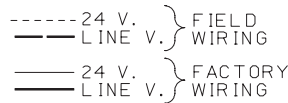

NOTES

1. BE SURE POWER SUPPLY AGREES WITH EQUIPMENT NAMEPLATE(S).
2. LOW VOLTAGE (24V.) WIRING TO BE NO. 18 AWG MIN.
3. GROUNDING OF EQUIPMENT MUST COMPLY WITH LOCAL CODES.
4. SET THERMOSTAT HEAT ANTICIPATOR PER UNIT WIRING DIAGRAM.
5. THIS CONNECTION IS ONLY USED FOR THERMOSTATS REQUIRING CONNECTION TO THE 24 V. POWER SUPPLY. (COMMON)
6. WHEN A HEATING THERMOSTAT (WITHOUT FAN SWITCH) IS USED, NO WIRING ON "G" TERMINAL OF IFC IS USED.

TO 115 V 1 PH.,
60 HZ., POWER
SUPPLY PER
LOCAL CODES

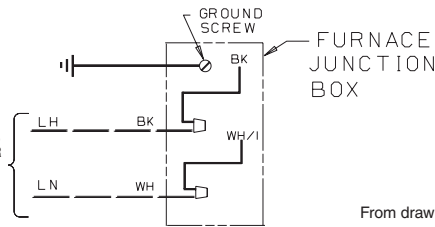

From drawing B342026 Rv 0

FIELD WIRING DIAGRAM FOR HEATING/COOLING (OUTDOOR SECTION WITHOUT TRANSFORMER)

FIELD WIRING DIAGRAM FOR 1 STAGE FURNACE 1 STAGE HEATING, 1 STAGE COOLING USING A 1 STAGE HEATING, 1 STAGE COOLING THERMOSTAT (OUTDOOR SECTION WITHOUT TRANSFORMER)

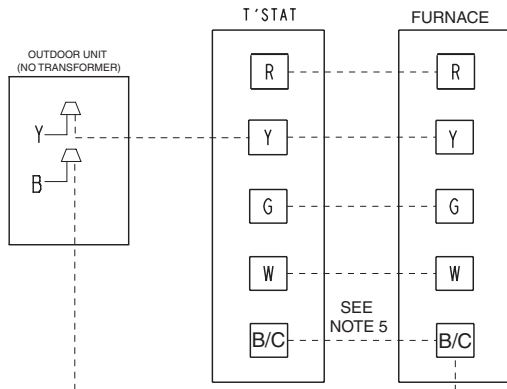

INTER-COMPONENT WIRING

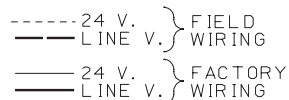

NOTES

1. BE SURE POWER SUPPLY AGREES WITH EQUIPMENT NAMEPLATE(S).
2. LOW VOLTAGE (24V.) WIRING TO BE NO. 18 AWG MIN.
3. GROUNDING OF EQUIPMENT MUST COMPLY WITH LOCAL CODES.
4. SET THERMOSTAT HEAT ANTICIPATOR PER UNIT WIRING DIAGRAM.
5. THIS CONNECTION IS ONLY USED FOR THERMOSTATS REQUIRING CONNECTION TO THE 24 V. POWER SUPPLY. (COMMON)

TO 115 V 1 PH.,
60 HZ., POWER
SUPPLY PER
LOCAL CODES

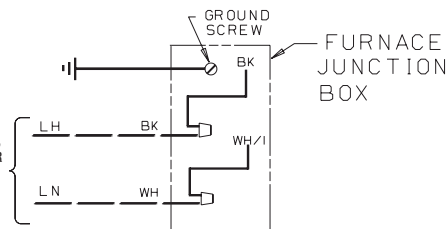

From drawing B342023 Rv 0

Dimensions

AUE1 OUTLINE DRAWING (ALL DIMENSIONS ARE IN INCHES)

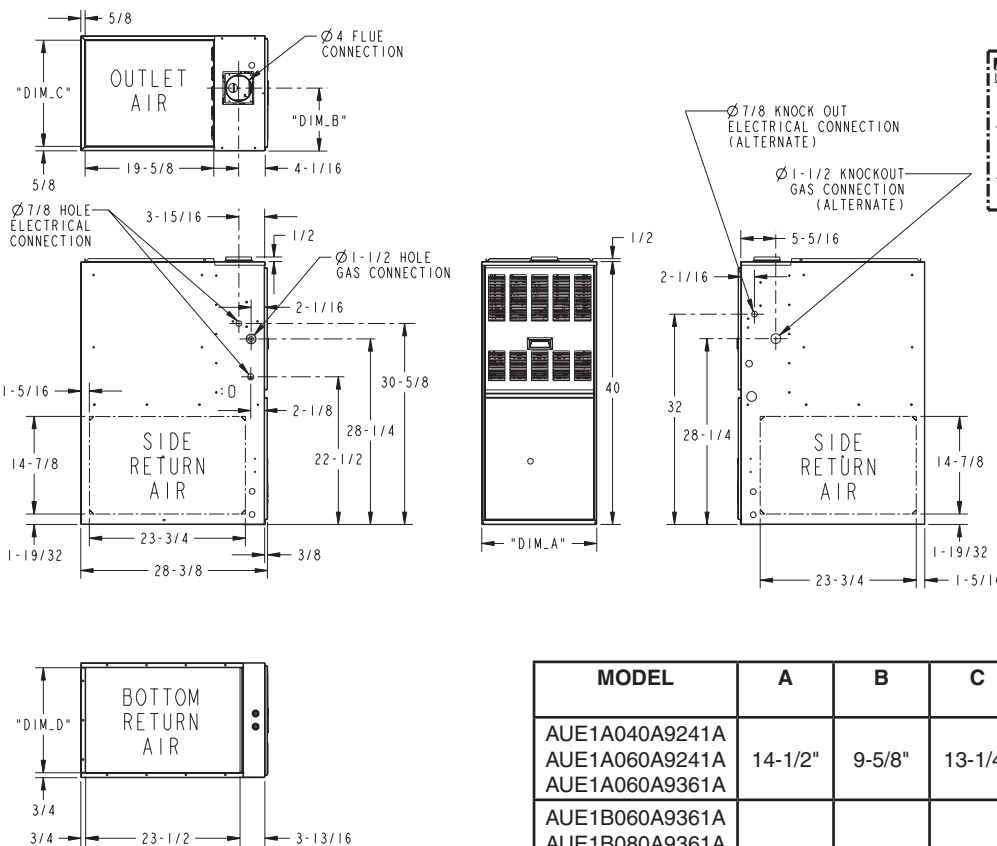

MODEL	A	B	C	D
AUE1A040A9241A				
AUE1A060A9241A	14-1/2"	9-5/8"	13-1/4"	13"
AUE1A060A9361A				
AUE1B060A9361A				
AUE1B080A9361A	17-1/2"	9-5/8"	16-1/4"	16"
AUE1B080A9481A				
AUE1B100A9361A				
AUE1C100A9481A	21"	13-1/16"	19-3/4"	19-1/2"
AUE1C100A9601A				
AUE1D120A9601A	24-1/2"	15-5/16"	23-1/4"	23"
AUE1D140A9601A				

From Dwg. 21C340781 Rev. 13

Notes



A series of horizontal lines for writing notes, consisting of 25 evenly spaced lines that fill the majority of the page.

American Standard
HEATING & AIR CONDITIONING

American Standard
Heating & Air Conditioning
6200 Troup Highway
Tyler, TX 75707



06/12

Since American Standard Heating & Air Conditioning has a policy of continuous product and product data improvement, it reserves the right to change design and specifications without notice.