

American Standard

HEATING & AIR CONDITIONING

Upflow/ Horizontal Downflow/Horizontal Condensing, Direct Vent Gas-Fired Furnace

FREEDOM 95

**AUH1B040A9241A, AUH1B060A9361A,
AUH1B080A9421B, AUH1C080A9601A,
AUH1C100A9481A, AUH1D100A9601A,
AUH1D120A9601A, ADH1B040A9241A,
ADH1B065A9421A, ADH1C085A9481A,
ADH1D110A9601A**

**Single-Stage Fan Assisted
Combustion System**

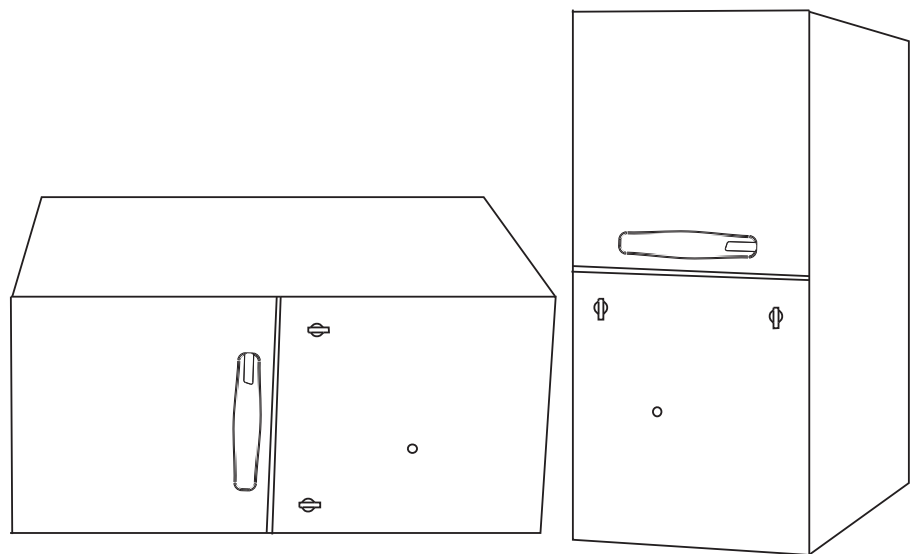

PUB. NO. 12-1292-08

General Features

NATURAL GAS MODELS

Central Heating furnace designs are certified to ANSI Z21.47 / CSA 2.3 for both natural and L.P. gas. Limit setting and rating data were established and approved under standard rating conditions using American National Standards Institute standards.

SAFE OPERATION

The Integrated System Control has solid state devices, which continuously monitor for presence of flame, when the system is in the heating mode of operation. Dual solenoid combination gas valve and regulator provide extra safety.

QUICK HEATING

Durable, cycle tested, heavy gauge **aluminized steel heat exchanger** quickly transfers heat to provide warm conditioned air to the structure. **Low energy power vent blower**, to increase efficiency and provide a positive discharge of gas fumes to the outside.

BURNERS

Multiport Inshot burners will give years of quiet and efficient service. All models can be converted to **L.P. gas** without changing burners.

INTEGRATED SYSTEM CONTROL

Exclusively designed operational program provides total control of furnace limit sensors, blowers, gas valve, flame control and includes self diagnostics for ease of service. Also contains connection points for E.A.C./humidifier.

AIR DELIVERY

The four speed, direct drive blower motor, has sufficient airflow for most heating and cooling requirements, will switch from heating to cooling speeds on demand from room thermostat. The blower door safety switch will prevent or terminate furnace operation when the blower door is removed.

STYLING

Heavy gauge steel and “wrap-around” cabinet construction is used in the cabinet with baked-on enamel finish for strength and beauty. The heat exchanger section of the cabinet is completely lined with foil faced fiberglass insulation. This results in quiet and efficient operation due to the excellent acoustical and insulating qualities of fiberglass. Built-in bottom pan and alternate bottom, left or right side return air connection provision.

FEATURES AND

GENERAL OPERATION

The FREEDOM 95 High Efficiency Gas Furnaces employ a Silicon Nitride Hot Surface Ignition system, which eliminates the waste of a constant burning pilot. The integrated system control lights the main burners upon a demand for heat from the room thermostat. Complete front service access.

- a. Low energy power venter
- b. Vent proving pressure switch.

Features and Benefits

FREEDOM 95 Standard Equipment

- Power supply 115/1/60
- Convertible to horizontal
- **Type 29-4C™** stainless steel secondary heat exchanger
- Inner blower doors
- Direct drive, 4-speed motors
- Silicon Nitride igniter with adaptive heat up
- Accessory hook-up capability – Hum and EAC
- Quiet induced draft blower
- Blower door safety switch
- Dual solenoid combination gas valve & regulator
- PVC venting – 1 or 2 pipe vent option
- Left/right gas connection
- Selectable cooling fan off delay eliminates need for BAY24X045 time delay relay
- Single wire twinning
- Integrated solid state control with self-diagnostics
- 24 volt fuse
- Manual reset burner box limit
- **Optional extended warranties**

Contents

General Features	2
Features and Benefits	2
FREEDOM 95 Standard Equipment	2
FREEDOM 95 Optional Equipment	4
General Data	5
AUH1B040A9241A	5
AUH1B060A9361A	5
AUH1B080A9421B	5
AUH1C080A9601A	6
AUH1C100A9481A	6
AUH1D100A9601A	6
AUH1D120A9601A	6
ADH1B040A9241A	7
ADH1B065A9421A	7
ADH1C085A9481A	7
ADH1D110A9601A	7
Performance Data	8
Electrical Data	10
Field Wiring	14
Twinning Field Wiring	15
Dimensions	16

Features and Benefits

FREEDOM 95 Optional Equipment

Comfort Control, Programmable 7 Day, 3-Ht, 2-CI	ACONT803AS32DA []
Comfort Control, Electric, 3-Ht, 2-CI (Non-programmable).....	ACONT402AN32DA []
For additional comfort control choices, see the product catalog or quick select handbook	
Propane Conversion Kit.....	BAYLPKT210B []
Propane Conversion Kit (stainless steel burners).....	BAYLPSS210B []
Downflow Subbase.....	BAYBASE205 []
Filter Access Door Kit.....	BAYFLTR206 []
Side Filter Rack.....	BAYFLTR200 []
High Altitude Pressure Switch Kit AUH1B040, ADH1B040, ADH1C085	BAYSWT01AHALTA []
High Altitude Pressure Switch Kit AUH1B060, AUH1D100, AUH1D120	BAYSWT04AHALTA []
High Altitude Pressure Switch Kit AUH1B080, AUH1C100, ADH1D110	BAYSWT05AHALTA []
High Altitude Pressure Switch Kit AUH1C080	BAYSWT11AHALTA []
High Altitude Pressure Switch Kit ADH1B065	BAYSWT12AHALTA []
Concentric Vent Kit.....	BAYAIR30AVENTA []
Sidewall Vent Termination Kit.....	BAYVENT200B []
Manufactured/Mobile Home Kit	BAYMFGH100A []

General Data

Product Specifications ^①

MODEL	AUH1B040A9241A	AUH1B060A9361A	AUH1B080A9421B
TYPE	Upflow / Horizontal	Upflow / Horizontal	Upflow / Horizontal
RATINGS ^②			
Input BTUH	40,000	60,000	77,000
Capacity BTUH (ICS) ^③	38,000	57,000	73,150
AFUE (ICS)	95.0	95.0	95.0
Temp. rise (Min.-Max.) °F.	30 - 60	30 - 60	35 - 65
BLOWER DRIVE	DIRECT	DIRECT	DIRECT
Diameter - Width (In.)	9 x 7	10 x 7	11 x 8
No. Used	1	1	1
Speeds (No.)	4	4	4
CFM vs. in. w.g.	See Fan Performance Table	See Fan Performance Table	See Fan Performance Table
Motor HP	1/5	1/3	1/2
R. P.M.	1075	1075	1075
Volts / Ph / Hz	115/1/60	115/1/60	115/1/60
COMBUSTION FAN - Type	Centrifugal	Centrifugal	Centrifugal
Drive - No. Speeds	Direct - 1	Direct - 1	Direct - 1
Motor HP - RPM	1/55 - 3000	1/55 - 3450	1/24 - 3450
Volts / Ph / Hz	115/1/60	115/1/60	115/1/60
FLA	1.0	1.75	0.71
FILTER — Furnished?	No	No	No
Type Recommended	High Velocity	High Velocity	High Velocity
Hi Vel. (No.-Size-Thk.)	1 - 17x25 - 1in.	1 - 17x25 - 1in.	1 - 17x25 - 1in.
VENT PIPE DIAMETER — Min (In.) ^{⑤⑥}	2 Round	2 Round	2 Round
HEAT EXCHANGER			
Type-Fired	Aluminized Steel - Type I	Aluminized Steel - Type I	Aluminized Steel - Type I
-Unfired			
Gauge (Fired)	20	20	20
ORIFICES — Main			
Nat. Gas. Qty. — Drill Size	2 — 45	3 — 45	4 — 45
L.P. Gas Qty. — Drill Size	2 — 56	3 — 56	4 — 56
GAS VALVE	Redundant - Single Stage	Redundant - Single Stage	Redundant - Single Stage
PILOT SAFETY DEVICE			
Type	Hot Surface Ignition	Hot Surface Ignition	Hot Surface Ignition
BURNERS — Type	Multiport Inshot	Multiport Inshot	Multiport Inshot
Number	2	3	4
POWER CONN. — V / Ph / Hz ^④	115/1/60	115/1/60	115/1/60
Ampacity (In Amps)	5.2	9.2	10.2
Max. Overcurrent Protection (Amps)	15	15	15
PIPE CONN. SIZE (IN.)	1/2	1/2	1/2
DIMENSIONS	H x W x D	H x W x D	H x W x D
Crated (In.)	41-3/4 x 19-1/2 x 30-1/2	41-3/4 x 19-1/2 x 30-1/2	41-3/4 x 19-1/2 x 30-1/2
WEIGHT			
Shipping (Lbs.) / Net (Lbs)	139 / 129	150 / 140	158 / 148

Notes

- ① Central Furnace heating designs are certified to ANSI Z21.47 / CSA 2.3
- ② For U.S. applications, above input ratings (BTUH) are up to 2,000 feet, derate 4% per 1,000 feet for elevations above 2,000 feet above sea level. For Canadian applications, above input ratings (BTUH) are up to 4,500 feet, derate 4% per 1,000 feet for elevations above 4,500 feet above sea level.
- ③ Based on U.S. government standard tests.
- ④ The above wiring specifications are in accordance with National Electrical Code; however, installations must comply with local codes.
- ⑤ Refer to the Vent Length Table in the Installer's Guide or the Allowable Vent Length label located on the furnace.
- ⑥ All *UH1 and *DH1 furnace models have a vent outlet diameter that equals 2".

General Data

Product Specifications ①

MODEL	AUH1C080A9601A	AUH1C100A9481A	AUH1D100A9601A	AUH1D120A9601A
TYPE	Upflow / Horizontal	Upflow / Horizontal	Upflow / Horizontal	Upflow / Horizontal
RATINGS ②				
Input BTUH	80,000	97,000	97,000	110,000
Capacity BTUH (ICS) ③	76,000	92,150	92,150	104,500
AFUE (ICS)	95.0	95.0	95.0	95.0
Temp. rise (Min.-Max.) °F.	30 - 60	35 - 65	35 - 65	40 - 70
BLOWER DRIVE				
Diameter - Width (In.)	DIRECT 11 x 10	DIRECT 10 x 10	DIRECT 11 x 10	DIRECT 11 x 10
No. Used	1	1	1	1
Speeds (No.)	4	4	4	4
CFM vs. in. w.g.	See Fan Performance Table	See Fan Performance Table	See Fan Performance Table	See Fan Performance Table
Motor HP	3/4	1/2	3/4	3/4
R.P.M.	1100	1075	1100	1100
Volts/Ph/Hz	115/1/60	115/1/60	115/1/60	115/1/60
COMBUSTION FAN - Type				
Drive - No. Speeds	Centrifugal Direct - 1	Centrifugal Direct - 1	Centrifugal Direct - 1	Centrifugal Direct - 1
Motor HP - RPM	1/20 - 3450	1/20 - 3450	1/20 - 3450	1/20 - 3450
Volts/Ph/Hz	115/1/60	115/1/60	115/1/60	115/1/60
FLA	0.71	0.71	0.71	0.71
FILTER — Furnished?				
Type Recommended	No	No	No	No
Hi Vel. (No.-Size-Thk.)	High Velocity 1 - 20x25 - 1in.	High Velocity 1 - 20x25 - 1in.	High Velocity 1 - 24x25 - 1in.	High Velocity 1 - 24x25 - 1in.
VENT PIPE DIAMETER —				
Min (In.) ⑤ ⑥	3 Round	3 Round	3 Round	3 Round
HEAT EXCHANGER				
Type-Fired	Aluminized Steel - Type I	Aluminized Steel - Type I	Aluminized Steel - Type I	Aluminized Steel - Type I
-Unfired				
Gauge (Fired)	20	20	20	20
ORIFICES — Main				
Nat. Gas Qty. — Drill Size	4 — 45	5 — 45	5 — 45	6 — 45
L.P. Gas Qty. — Drill Size	4 — 56	5 — 56	5 — 56	6 — 56
GAS VALVE				
	Redundant - Single Stage	Redundant - Single Stage	Redundant - Single Stage	Redundant - Single Stage
PILOT SAFETY DEVICE				
Type	Hot Surface Ignition	Hot Surface Ignition	Hot Surface Ignition	Hot Surface Ignition
BURNERS — Type				
Number	Multiport Inshot 4	Multiport Inshot 5	Multiport Inshot 5	Multiport Inshot 6
POWER CONN. — V/Ph/Hz ④				
Ampacity (In Amps)	115/1/60 13.5	115/1/60 12.5	115/1/60 12.9	115/1/60 12.9
Max. Overcurrent Protection (Amps)	20	20	20	20
PIPE CONN. SIZE (IN.)				
	1/2	1/2	1/2	1/2
DIMENSIONS				
Crated (In.)	H x W x D 41-3/4 x 23 x 30-1/2	H x W x D 41-3/4 x 23 x 30-1/2	H x W x D 41-3/4 x 26-1/2 x 30-1/2	H x W x D 41-3/4 x 26-1/2 x 30-1/2
WEIGHT				
Shipping (Lbs.)/Net (Lbs)	171 / 160	171 / 160	197 / 185	205 / 193

Notes

- ① Central Furnace heating designs are certified to ANSI Z21.47 / CSA 2.3
- ② For U.S. applications, above input ratings (BTUH) are up to 2,000 feet, derate 4% per 1,000 feet for elevations above 2,000 feet above sea level. For Canadian applications, above input ratings (BTUH) are up to 4,500 feet, derate 4% per 1,000 feet for elevations above 4,500 feet above sea level.
- ③ Based on U.S. government standard tests.
- ④ The above wiring specifications are in accordance with National Electrical Code; however, installations must comply with local codes.
- ⑤ Refer to the Vent Length Table in the Installer's Guide or the Allowable Vent Length label located on the furnace.
- ⑥ All *UH1 and *DH1 furnace models have a vent outlet diameter that equals 2".

General Data

Product Specifications ^①

MODEL	ADH1B040A9241A	ADH1B065A9421A	ADH1C085A9481A	ADH1D110A9601A
TYPE	Downflow / Horizontal	Downflow / Horizontal	Downflow / Horizontal	Downflow / Horizontal
RATINGS ^②				
Input BTUH	40,000	60,000	80,000	110,000
Capacity BTUH (ICS) ^③	38,000	57,000	76,000	104,500
AFUE (ICS)	95.0	95.0	95.0	95.0
Temp. rise (Min.-Max.) °F.	30 - 60	25 - 55	30 - 60	35 - 65
BLOWER DRIVE	DIRECT	DIRECT	DIRECT	DIRECT
Diameter - Width (In.)	10 x 7	11 x 8	11 x 10	11 x 10
No. Used	1	1	1	1
Speeds (No.)	4	4	4	4
CFM vs. in. w.g.	See Fan Performance Table	See Fan Performance Table	See Fan Performance Table	See Fan Performance Table
Motor HP	1/5	1/2	1/2	3/4
R.P.M.	1080	1075	1075	1100
Volts/Ph/Hz	115/1/60	115/1/60	115/1/60	115/1/60
COMBUSTION FAN - Type	Centrifugal	Centrifugal	Centrifugal	Centrifugal
Drive - No. Speeds	Direct - 1	Direct - 1	Direct - 1	Direct - 1
Motor HP - RPM	1/55 - 3000	1/25 - 3200	1/20 - 3450	1/20 - 3450
Volts/Ph/Hz	115/1/60	115/1/60	115/1/60	115/1/60
FLA	1.14	1.35	0.71	0.71
FILTER — Furnished?	No	No	No	No
Type Recommended	High Velocity	High Velocity	High Velocity	High Velocity
Hi Vel. (No.-Size-Thk.)	2 - 14x20 - 1in.	2 - 14x20 - 1in.	2 - 16x20 - 1in.	2 - 16x20 - 1in.
VENT PIPE DIAMETER — Min (In.) ^{⑤⑥}	2 Round	2 Round	2.5 Round	2.5 Round
HEAT EXCHANGER				
Type-Fired	Aluminized Steel - Type I	Aluminized Steel - Type I	Aluminized Steel - Type I	Aluminized Steel - Type I
-Unfired				
Gauge (Fired)	20	20	20	20
ORIFICES — Main				
Nat. Gas. Qty. — Drill Size	2 — 45	4 — 48	5 — 48	6 — 48
L.P. Gas Qty. — Drill Size	2 — 56	4 — 56	5 — 56	6 — 56
GAS VALVE	Redundant - Single Stage	Redundant - Single Stage	Redundant - Single Stage	Redundant - Single Stage
PILOT SAFETY DEVICE				
Type	Hot Surface Ignition	Hot Surface Ignition	Hot Surface Ignition	Hot Surface Ignition
BURNERS — Type	Multiport Inshot	Multiport Inshot	Multiport Inshot	Multiport Inshot
Number	2	4	5	6
POWER CONN. — V/Ph/Hz ^④	115/1/60	115/1/60	115/1/60	115/1/60
Ampacity (In Amps)	4.8	11.4	12.5	12.9
Max. Overcurrent Protection (Amps)	15	15	20	20
PIPE CONN. SIZE (IN.)	1/2	1/2	1/2	1/2
DIMENSIONS	H x W x D	H x W x D	H x W x D	H x W x D
Crated (In.)	41-3/4 x 19-1/2 x 30-1/2	41-3/4 x 19-1/2 x 30-1/2	41-3/4 x 23 x 30-1/2	41-3/4 x 26-1/2 x 30-1/2
WEIGHT				
Shipping (Lbs.)/Net (Lbs)	145 / 135	158 / 148	171 / 160	205 / 193

Notes

- ① Central Furnace heating designs are certified to ANSI Z21.47 / CSA 2.3
- ② For U.S. applications, above input ratings (BTUH) are up to 2,000 feet, derate 4% per 1,000 feet for elevations above 2,000 feet above sea level. For Canadian applications, above input ratings (BTUH) are up to 4,500 feet, derate 4% per 1,000 feet for elevations above 4,500 feet above sea level.
- ③ Based on U.S. government standard tests.
- ④ The above wiring specifications are in accordance with National Electrical Code; however, installations must comply with local codes.
- ⑤ Refer to the Vent Length Table in the Installer's Guide or the Allowable Vent Length label located on the furnace.
- ⑥ All *UH1 and *DH1 furnace models have a vent outlet diameter that equals 2".

Performance Data

FURNACE AIRFLOW (CFM) VS. EXTERNAL STATIC PRESSURE (in. w.c.)										
MODEL	SPEED TAP	0.10	0.20	0.30	0.40	0.50	0.60	0.70	0.80	0.90
*UH1B040A9241A	4 - HIGH - Black	1043	992	930	885	812	740	647	518	457
	3 - MED.-HIGH - Blue	940	895	841	791	726	650	559	420	390
	2 - MED.-LOW - Yellow	837	798	752	705	649	560	438	305	279
	1 - LOW - Red	729	694	657	600	545	478	376	220	178
*UH1B060A9361A	4 - HIGH - Black	1359	1313	1264	1204	1144	1079	1004	919	812
	3 - MED.-HIGH - Blue	1232	1199	1161	1116	1065	1004	934	852	744
	2 - MED.-LOW - Yellow	1077	1054	1027	994	953	904	845	768	666
	1 - LOW - Red	926	913	895	871	836	792	733	670	570
*UH1B080A9421B	4 - HIGH - Black	1646	1611	1573	1530	1477	1421	1360	1289	1200
	3 - MED.-HIGH - Blue	1366	1356	1337	1311	1280	1243	1197	1139	1060
	2 - MED.-LOW - Yellow	1175	1159	1145	1130	1108	1081	1045	993	929
	1 - LOW - Red	1004	994	997	982	963	943	907	866	824
*UH1C080A9601A	4 - HIGH - Black	2235	2194	2152	2105	2057	1987	1916	1836	1757
	3 - MED.-HIGH - Blue	1921	1904	1888	1861	1835	1797	1760	1698	1636
	2 - MED.-LOW - Yellow	1618	1604	1591	1577	1563	1539	1515	1466	1416
	1 - LOW - Red	1334	1331	1327	1320	1313	1290	1266	1229	1192
*UH1C100A9481A	4 - HIGH - Black	1982	1912	1836	1761	1679	1593	1496	1389	1267
	3 - MED.-HIGH - Blue	1892	1832	1765	1696	1621	1538	1446	1342	1205
	2 - MED.-LOW - Yellow	1759	1712	1660	1604	1536	1465	1383	1275	1149
	1 - LOW - Red	1593	1557	1521	1485	1433	1370	1294	1182	1068
*UH1D100A9601A	4 - HIGH - Black	2339	2287	2235	2168	2100	2021	1941	1858	1773
	3 - MED.-HIGH - Blue	2045	2021	1996	1947	1897	1836	1774	1701	1629
	2 - MED.-LOW - Yellow	1719	1703	1693	1671	1649	1607	1565	1498	1431
	1 - LOW - Red	1436	1430	1430	1414	1398	1372	1344	1287	1230
*UH1D120A9601A	4 - HIGH - Black	2380	2334	2287	2241	2193	2118	2043	1956	1870
	3 - MED.-HIGH - Blue	2042	2029	2016	1984	1952	1892	1830	1771	1712
	2 - MED.-LOW - Yellow	1695	1690	1684	1668	1652	1627	1601	1545	1489
	1 - LOW - Red	1402	1404	1406	1397	1387	1358	1328	1285	1242

*= First letter may be "A" or "T"

CFM VS. TEMPERATURE RISE																			
MODEL	Cubic Feet Per Minute (CFM)																		
	600	700	800	900	1000	1100	1200	1300	1400	1500	1600	1700	1800	1900	2000	2100	2200	2300	2400
*UH1B040A9241A	59	50	44	39	35														
*UH1B060A9361A				59	53	48	44	41	38										
*UH1B080A9421B						64	59	54	50	47	44	41							
*UH1C080A9601A						64	59	54	50	47	44	41							
*UH1C100A9481A								68	63	59	55	52	49	46	44				
*UH1D100A9601A								68	63	59	55	52	49	46	44	42	40	38	37
*UH1D120A9601A										70	66	62	59	56	53	50	48	46	44

*= First letter may be "A" or "T"

Performance Data

FURNACE AIRFLOW (CFM) VS. EXTERNAL STATIC PRESSURE (in. w.c.)										
MODEL	SPEED TAP	0.10	0.20	0.30	0.40	0.50	0.60	0.70	0.80	0.90
*DH1B040A9241A	4 - HIGH - Black	998	965	922	870	807	735	653	561	459
	3 - MED.-HIGH - Blue	856	832	797	751	695	628	550	462	363
	2 - MED.-LOW - Yellow	753	728	694	650	596	533	460	378	286
	1 - LOW - Red	647	617	581	538	490	435	375	308	235
*DH1B065A9421A	4 - HIGH - Black	1501	1453	1402	1344	1283	1216	1145	1068	986
	3 - MED.-HIGH - Blue	1442	1393	1341	1285	1227	1166	1103	1037	968
	2 - MED.-LOW - Yellow	1346	1308	1263	1212	1155	1092	1024	950	869
	1 - LOW - Red	1225	1197	1160	1116	1062	1001	931	853	766
*DH1C085A9481A	4 - HIGH - Black	1835	1772	1709	1637	1566	1485	1405	1313	1222
	3 - MED.-HIGH - Blue	1726	1674	1622	1557	1492	1416	1340	1252	1164
	2 - MED.-LOW - Yellow	1581	1539	1498	1440	1383	1321	1258	1172	1085
	1 - LOW - Red	1401	1374	1346	1308	1269	1209	1148	1075	1001
*DH1D110A9601A	4 - HIGH - Black	2147	2074	2000	1941	1881	1807	1732	1655	1576
	3 - MED.-HIGH - Blue	1995	1940	1885	1827	1767	1699	1631	1547	1462
	2 - MED.-LOW - Yellow	1712	1681	1649	1602	1555	1505	1455	1381	1307
	1 - LOW - Red	1424	1408	1392	1367	1341	1296	1251	1188	1124

*= First letter may be "A" or "T"

CFM VS. TEMPERATURE RISE																	
MODEL	Cubic Feet Per Minute (CFM)																
	600	700	800	900	1000	1100	1200	1300	1400	1500	1600	1700	1800	1900	2000	2100	2200
*DH1B040A9241A	59	50	44	39	35												
*DH1B065A9421A		75	66	59	53	48	44	41	38	35							
*DH1C085A9481A					70	64	59	54	50	47	44	41	39	37			
*DH1D110A9601A						88	81	74	69	65	60	57	54	51	48	46	

*= First letter may be "A" or "T"

Electrical Data

AUH1 Wiring

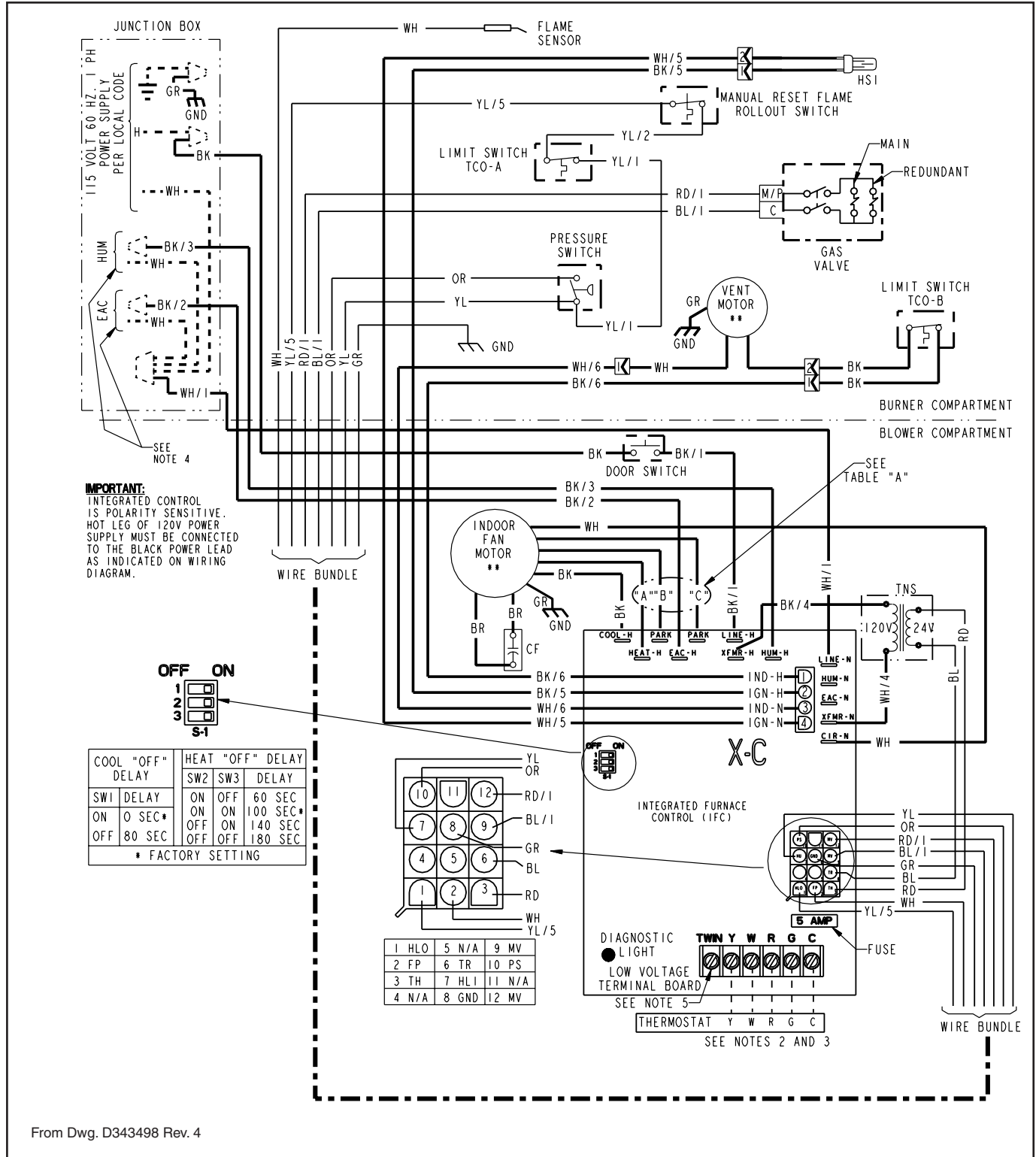

From Dwg. D343498 Rev. 4

Electrical Data

AUH1 Schematic

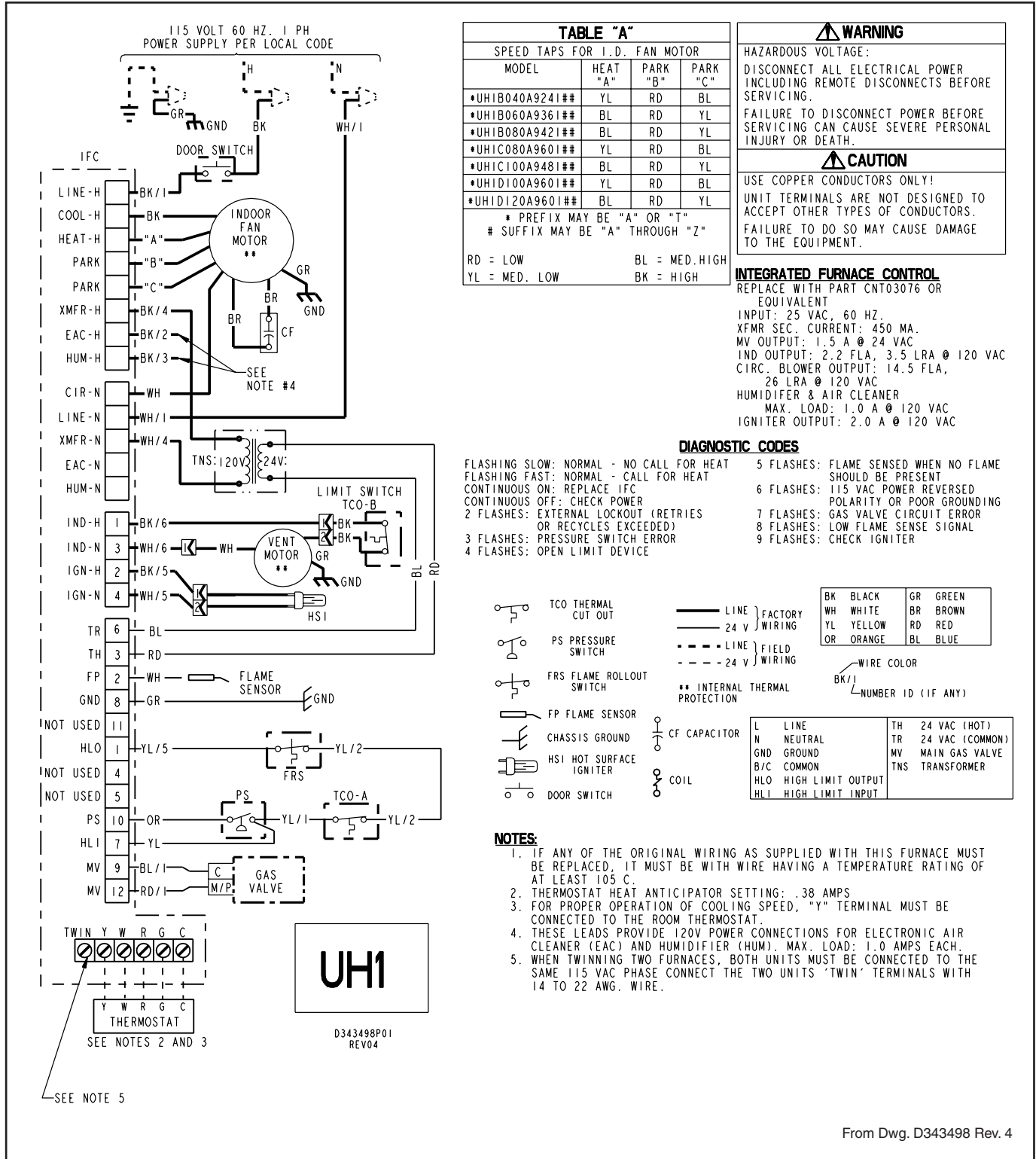

TABLE "A"
SPEED TAPS FOR I.D. FAN MOTOR

MODEL	HEAT "A"	PARK "B"	PARK "C"
*UH1B040A9241##	YL	RD	BL
*UH1B060A9361##	BL	RD	YL
*UH1B080A9421##	BL	RD	YL
*UH1C080A9601##	YL	RD	BL
*UH1C100A9481##	BL	RD	YL
*UH1D100A9601##	YL	RD	BL
*UH1D120A9601##	BL	RD	YL

* PREFIX MAY BE "A" OR "T"
SUFFIX MAY BE "A" THROUGH "Z"

RD = LOW BL = MED. HIGH
YL = MED. LOW BK = HIGH

WARNING
HAZARDOUS VOLTAGE:
DISCONNECT ALL ELECTRICAL POWER INCLUDING REMOTE DISCONNECTS BEFORE SERVICING.
FAILURE TO DISCONNECT POWER BEFORE SERVICING CAN CAUSE SEVERE PERSONAL INJURY OR DEATH.

CAUTION
USE COPPER CONDUCTORS ONLY!
UNIT TERMINALS ARE NOT DESIGNED TO ACCEPT OTHER TYPES OF CONDUCTORS.
FAILURE TO DO SO MAY CAUSE DAMAGE TO THE EQUIPMENT.

INTEGRATED FURNACE CONTROL
REPLACE WITH PART CNT03076 OR EQUIVALENT
INPUT: 25 VAC, 60 HZ.
XFMR SEC. CURRENT: 450 MA.
MV OUTPUT: 1.5 A @ 24 VAC
IND OUTPUT: 2.2 FLA, 3.5 LRA @ 120 VAC
CIRC. BLOWER OUTPUT: 14.5 FLA, 26 LRA @ 120 VAC
HUMIDIFIER & AIR CLEANER
MAX. LOAD: 1.0 A @ 120 VAC
IGNITER OUTPUT: 2.0 A @ 120 VAC

DIAGNOSTIC CODES

FLASHING SLOW: NORMAL - NO CALL FOR HEAT
FLASHING FAST: NORMAL - CALL FOR HEAT
CONTINUOUS ON: REPLACE IFC
CONTINUOUS OFF: CHECK POWER

5 FLASHES: FLAME SENSED WHEN NO FLAME SHOULD BE PRESENT
6 FLASHES: 115 VAC POWER REVERSED POLARITY OR POOR GROUNDING
7 FLASHES: GAS VALVE CIRCUIT ERROR
8 FLASHES: LOW FLAME SENSE SIGNAL
9 FLASHES: CHECK IGNITER

2 FLASHES: EXTERNAL LOCKOUT (RETRIES OR RECYCLES EXCEEDED)
3 FLASHES: PRESSURE SWITCH ERROR
4 FLASHES: OPEN LIMIT DEVICE

TCO THERMAL CUT OUT
 PS PRESSURE SWITCH
 FRS FLAME ROLLOUT SWITCH
 FP FLAME SENSOR
 CHASSIS GROUND
 HSI HOT SURFACE IGNITER
 DOOR SWITCH
 LINE 24 V WIRING
 FIELD WIRING
 24 V WIRING
 INTERNAL THERMAL PROTECTION
 CF CAPACITOR
 COIL

WIRE COLOR
 BK BLACK GR GREEN
 WH WHITE BR BROWN
 YL YELLOW RD RED
 OR ORANGE BL BLUE

TERMINAL IDENTIFICATION
 L LINE TH 24 VAC (HOT)
 N NEUTRAL TR 24 VAC (COMMON)
 GND GROUND MV MAIN GAS VALVE
 B/C COMMON TNS TRANSFORMER
 HLO HIGH LIMIT OUTPUT
 HLI HIGH LIMIT INPUT

- NOTES:**
- IF ANY OF THE ORIGINAL WIRING AS SUPPLIED WITH THIS FURNACE MUST BE REPLACED, IT MUST BE WITH WIRE HAVING A TEMPERATURE RATING OF AT LEAST 105 C.
 - THERMOSTAT HEAT ANTICIPATOR SETTING: .38 AMPS
 - FOR PROPER OPERATION OF COOLING SPEED, "Y" TERMINAL MUST BE CONNECTED TO THE ROOM THERMOSTAT.
 - THESE LEADS PROVIDE 120V POWER CONNECTIONS FOR ELECTRONIC AIR CLEANER (EAC) AND HUMIDIFIER (HUM). MAX. LOAD: 1.0 AMPS EACH.
 - WHEN TWINNING TWO FURNACES, BOTH UNITS MUST BE CONNECTED TO THE SAME 115 VAC PHASE CONNECT THE TWO UNITS 'TWIN' TERMINALS WITH 14 TO 22 AWG. WIRE.

UH1

D343498P01
REV04

Electrical Data

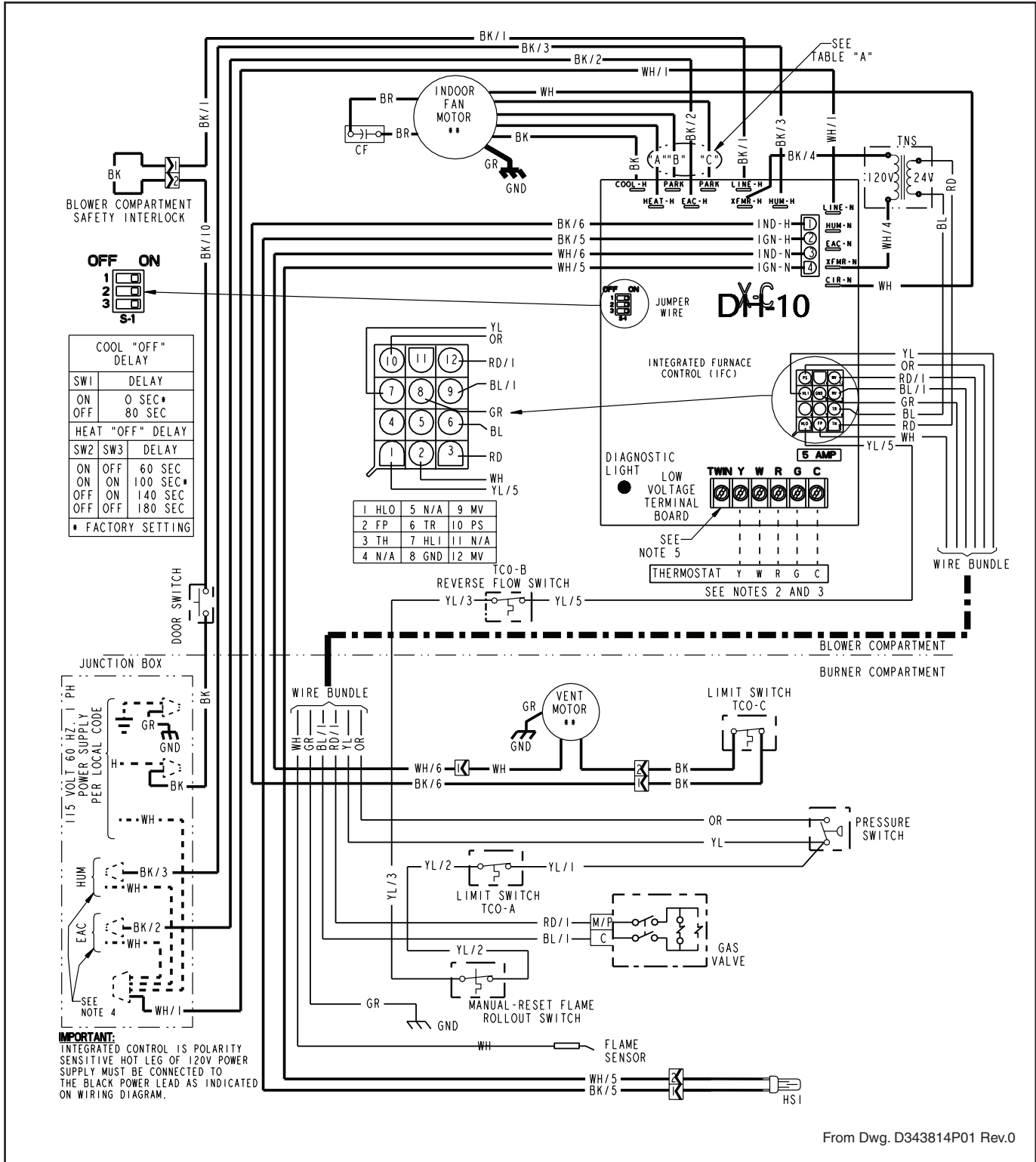

Electrical Data

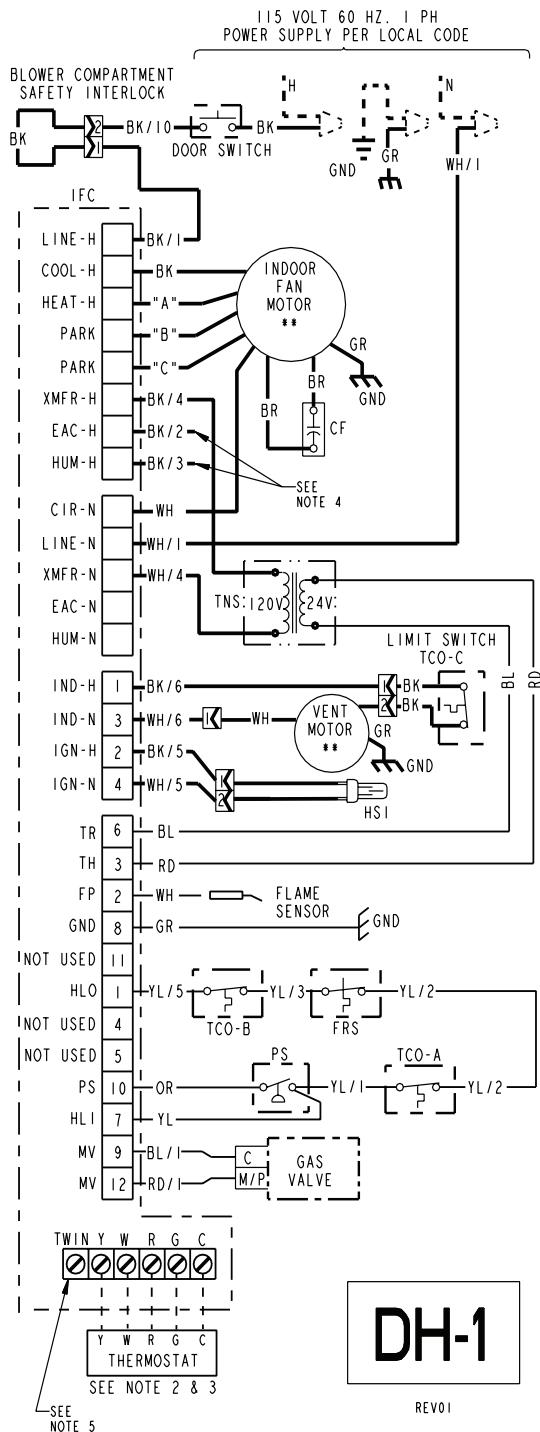

SPEED TAPS FOR I.D. FAN MOTOR			
MODEL	HEAT "A"	PARK "B"	PARK "C"
*DH1B040A9241A#	YL	RD	BL
*DH1B065A9421A#	BL	RD	YL
*DH1C085A9481A#	BL	RD	YL
*DH1D110A9601A#	BL	RD	YL

RD = LOW
YL = MED. LOW

BL = MED. HIGH
BK = HIGH

* - MAY BE PREFIX "A" OR "T"
- MAY BE SUFFIX "A" THROUGH "Z"

WARNING

HAZARDOUS VOLTAGE:
DISCONNECT ALL ELECTRICAL POWER INCLUDING REMOTE DISCONNECTS BEFORE SERVICING.
FAILURE TO DISCONNECT POWER BEFORE SERVICING CAN CAUSE SEVERE PERSONAL INJURY OR DEATH.

CAUTION

USE COPPER CONDUCTORS ONLY!
UNIT TERMINALS ARE NOT DESIGNED TO ACCEPT OTHER TYPES OF CONDUCTORS.
FAILURE TO DO SO MAY CAUSE DAMAGE TO THE EQUIPMENT.

INTEGRATED FURNACE CONTROL
REPLACE WITH PART CNT05995 OR EQUIVALENT
INPUT: 25 VAC, 60 HZ.
XFMR SEC. CURRENT: 450 MA.
MV OUTPUT: 1.5 A @ 24 VAC
IND OUTPUT: 2.2 FLA, 3.5 LRA @ 120 VAC
CIRC. BLOWER OUTPUT: 14.5 FLA, 26.0 LRA @ 120 VAC
HUMIDIFIER & AIR CLEANER
MAX. LOAD: 1.0 A @ 120 VAC
IGNITER OUTPUT: 6.0 A @ 120 VAC

DIAGNOSTIC CODES

- FLASHING SLOW: NORMAL - NO CALL FOR HEAT
FLASHING FAST: NORMAL - CALL FOR HEAT
CONTINUOUS ON: REPLACE IFC
CONTINUOUS OFF: CHECK POWER
- 2 FLASHES: EXTERNAL LOCKOUT (RETRIES OR RECYCLES EXCEEDED)
3 FLASHES: PRESSURE SWITCH ERROR
4 FLASHES: OPEN LIMIT DEVICE
- 5 FLASHES: FLAME SENSED WHEN NO FLAME SHOULD BE PRESENT
6 FLASHES: 115 VAC POWER REVERSED POLARITY OR POOR GROUNDING
7 FLASHES: GAS VALVE CIRCUIT ERROR
8 FLASHES: LOW FLAME SENSE SIGNAL
9 FLASHES: CHECK IGNITER

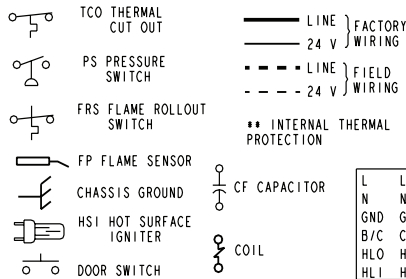

L	LINE	TH	24 VAC (HOT)
N	NEUTRAL	TR	24 VAC (COMMON)
GND	GROUND	MV	MAIN GAS VALVE
B/C	COMMON	TNS	TRANSFORMER
HLO	HIGH LIMIT OUTPUT		
HLI	HIGH LIMIT INPUT		

NOTES:

- IF ANY OF THE ORIGINAL WIRING AS SUPPLIED WITH THIS FURNACE MUST BE REPLACED, IT MUST BE WITH WIRE HAVING A TEMPERATURE RATING OF AT LEAST 105 C.
- THERMOSTAT HEAT ANTICIPATOR SETTING: .38 AMPS
- FOR PROPER OPERATION OF COOLING SPEED, "Y" TERMINAL MUST BE CONNECTED TO THE ROOM THERMOSTAT.
- THESE LEADS PROVIDE 120V POWER CONNECTIONS FOR ELECTRONIC AIR CLEANER (EAC) AND HUMIDIFIER (HUM). MAX. LOAD: 1.0 AMPS EACH.
- WHEN TWINNING TWO FURNACES, BOTH UNITS MUST BE CONNECTED TO THE SAME 115 VAC PHASE CONNECT THE TWO UNITS "TWIN" TERMINALS WITH 14 TO 22 AWG. WIRE.

DH-1

REV01

From Dwg. D343814P01 Rev.0

Field Wiring

FIELD WIRING DIAGRAM FOR 1 STAGE FURNACE 1 STAGE HEATING, 1 STAGE COOLING USING A 1 STAGE HEATING, 1 STAGE COOLING THERMOSTAT (OUTDOOR SECTION WITHOUT TRANSFORMER)

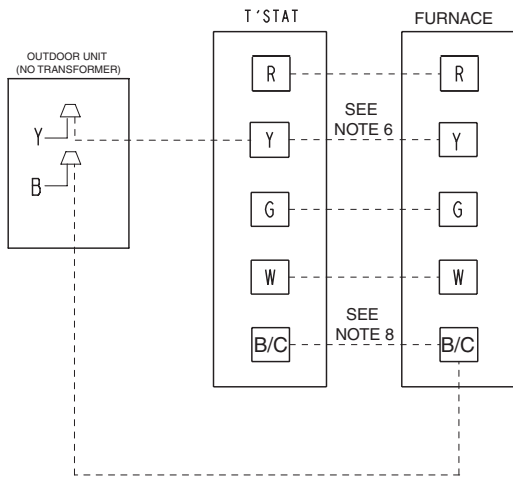

NOTES:

1. BE SURE POWER AGREES WITH EQUIPMENT NAMEPLATE(S)
2. LOW VOLTAGE (24 V. WIRING) TO BE NO. 18 A.W.G. MIN.
3. GROUNDING OF EQUIPMENT MUST COMPLY WITH LOCAL CODES.
4. SET THERMOSTAT HEAT ANTICIPATOR PER UNIT WIRING DIAGRAM.
5. THESE LEADS PROVIDE 115 V. POWER FOR CONNECTION OF ELECTRONIC AIR CLEANER AND HUMIDIFIER MAX. LOAD 1.0 AMPS EACH.
6. THE "Y" TERMINAL FROM THE THERMOSTAT MUST BE WIRED TO THE "Y" TERMINAL OF THE FURNACE CONTROL FOR PROPER BLOWER OPERATION DURING COOLING.
7. IGNITION CONTROL IS POLARITY SENSITIVE. HOT LEG OF 120 VOLT POWER SUPPLY MUST BE CONNECTED TO THE BLACK LINE POWER LEAD AS INDICATED ON THE WIRING DIAGRAM OR IGNITION LOCKOUT WILL OCCUR.
8. THIS CONNECTION IS ONLY USED FOR THERMOSTATS REQUIRING CONNECTION TO THE 24 V. POWER SUPPLY. (COMMON)

INTER-COMPONENT WIRING

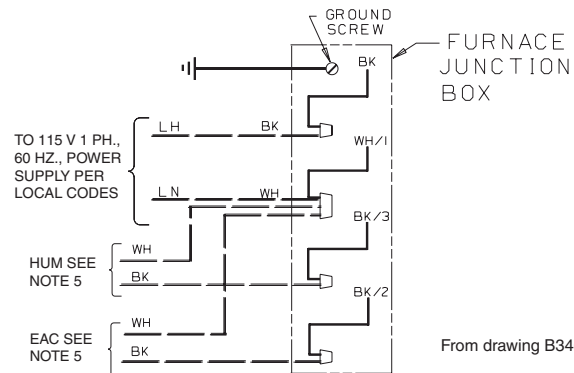
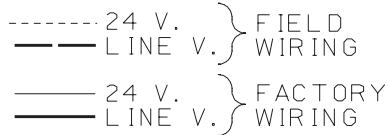

Twinning Field Wiring

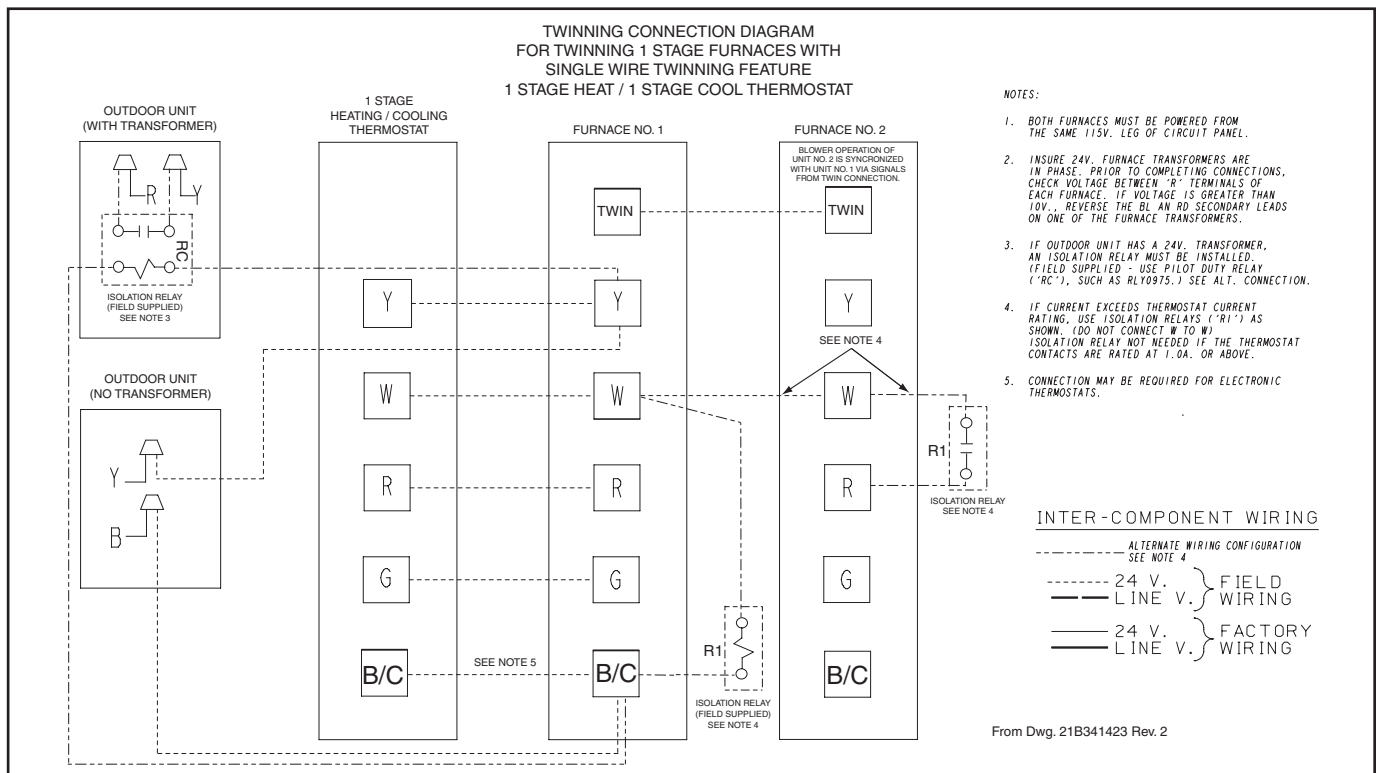
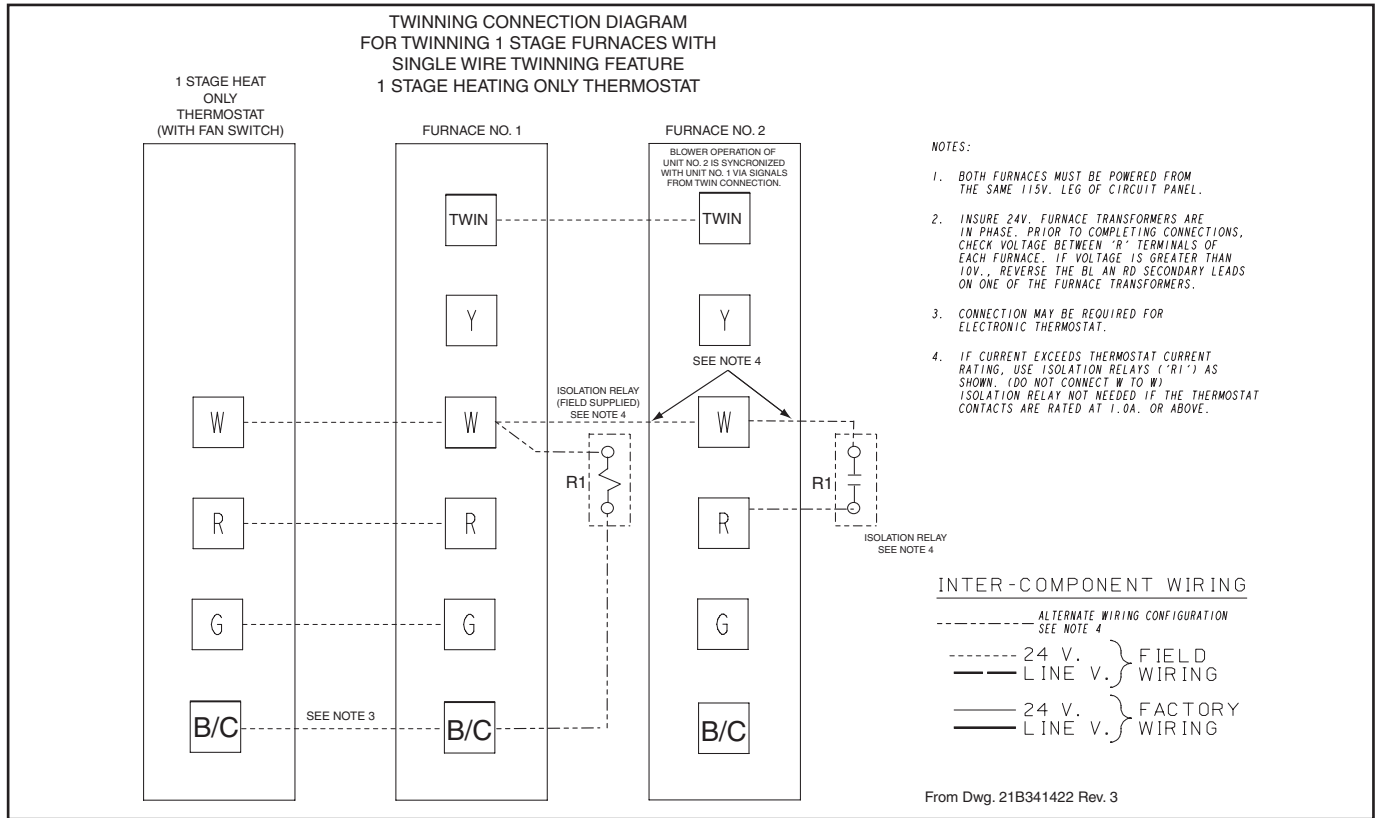

Dimensions

*UH1 OUTLINE DRAWING, UPFLOW / HORIZONTAL (ALL DIMENSIONS ARE IN INCHES)

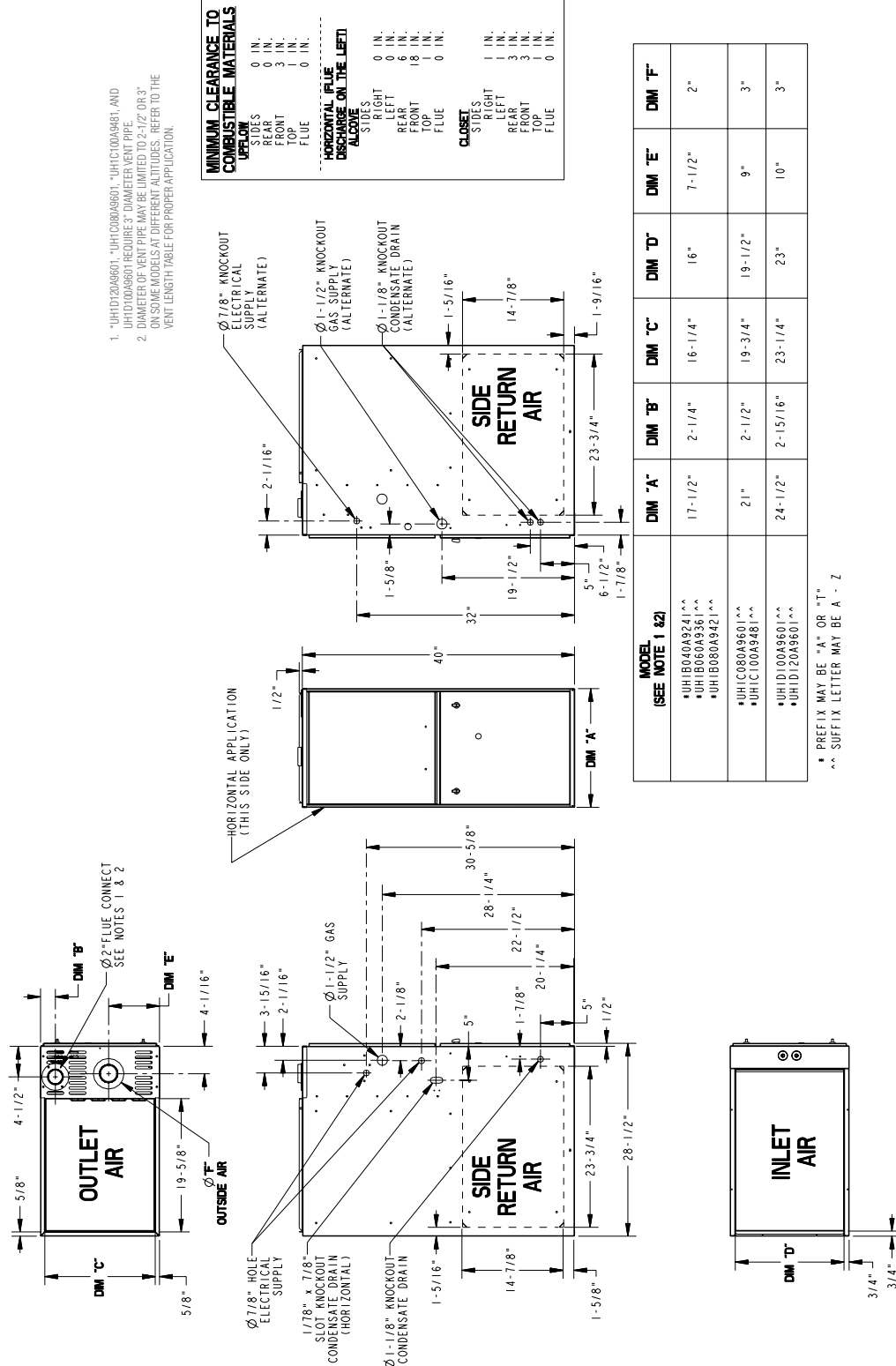

1. *UH1D120A9601, *UHC080A9601, *UHC100A9481, AND *UHD100A9601 REQUIRE 3" DIAMETER VENT PIPE.
2. DIAMETER OF VENT PIPE MAY BE LIMITED TO 2-1/2" OR 3" ON SOME MODELS AT DIFFERENT ALTITUDES. REFER TO THE VENT LENGTH TABLE FOR PROPER APPLICATION.

MODEL (SEE NOTE 1 & 2)	DIM "A"	DIM "B"	DIM "C"	DIM "D"	DIM "E"	DIM "F"
*UHB040A9241** *UHB060A9361** *UHB080A9421**	17-1/2"	2-1/4"	16-1/4"	16"	7-1/2"	2"
*UHC080A9601** *UHC100A9481**	21"	2-1/2"	19-3/4"	19-1/2"	9"	3"
*UHD100A9601** *UHD120A9601**	24-1/2"	2-15/16"	23-1/4"	23"	10"	3"

* PREFIX MAY BE "A" OR "T"
** SUFFIX LETTER MAY BE A - Z

From Dwg. C341884

Dimensions

*DH1 OUTLINE DRAWING, DOWNFLOW / HORIZONTAL (ALL DIMENSIONS ARE IN INCHES)

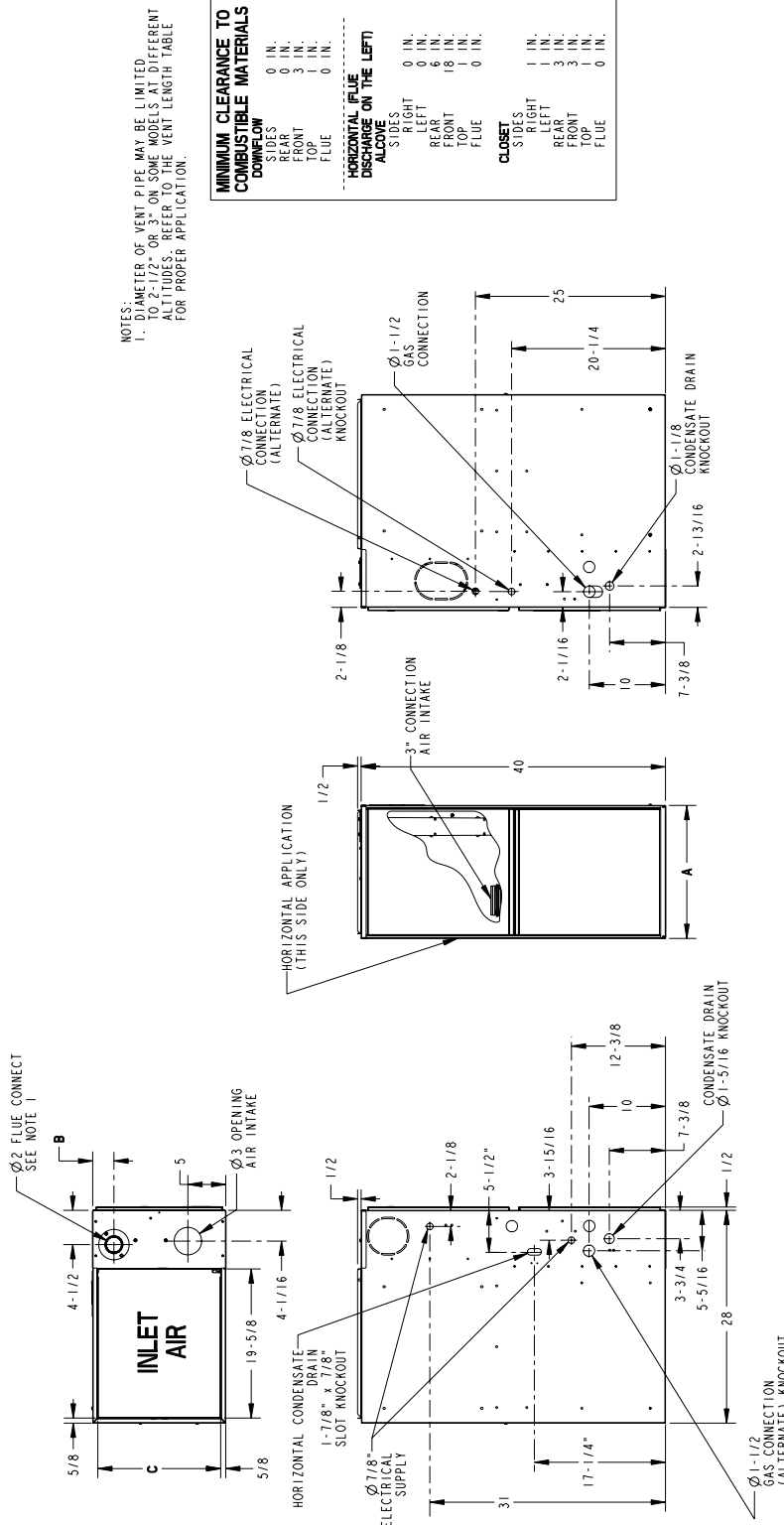

MINIMUM CLEARANCE TO COMBUSTIBLE MATERIALS	
DOWNFLOW	
SIDES	0 IN.
REAR	0 IN.
FRONT	3 IN.
TOP	1 IN.
FLUE	0 IN.
HORIZONTAL FLUE DISCHARGE ON THE LEFT	
ALCOVE	
SIDES	0 IN.
RIGHT	0 IN.
LEFT	6 IN.
REAR	18 IN.
FRONT	1 IN.
TOP	0 IN.
FLUE	0 IN.
CLOSET	
SIDES	1 IN.
LEFT	1 IN.
REAR	3 IN.
FRONT	3 IN.
TOP	1 IN.
FLUE	0 IN.

MODEL	DIM "A"	DIM "B"	DIM "C"	DIM "D"
*DH1B040A9241	17-1/2"	2-1/4"	16-1/4"	16"
*DH1B065A9421	21"	2-1/2"	19-3/4"	19-1/2"
*DH1C085A9481	24-1/2"	2-15/16"	23-1/4"	23"

* May be "A" or "T"
Part numbers can end in A-Z

From Dwg. C341885 Rev. 7



American Standard
HEATING & AIR CONDITIONING

American Standard
Heating & Air Conditioning
6200 Troup Highway
Tyler, TX 75707
www.americanstandardair.com

Literature Order Number	12-1292-08
File Number	12-1292-08
Supersedes	12-1292-07
Date	08/12

American Standard Heating & Air Conditioning has a policy of continuous product and product data improvement and it reserves the right to change design and specifications without notice.